

THIS DRAWING IS UNPUBLISHED.

RELEASED FOR PUBLICATION

© COPYRIGHT 19

ALL RIGHTS RESERVED.

LOC
AP

DIST
-

REVISIONS

P	LTR	DESCRIPTION	DATE	DWN	APVD
	DI	OBSOLETE DASH I ECO-13-006169	09APR2013	NCL	DAO

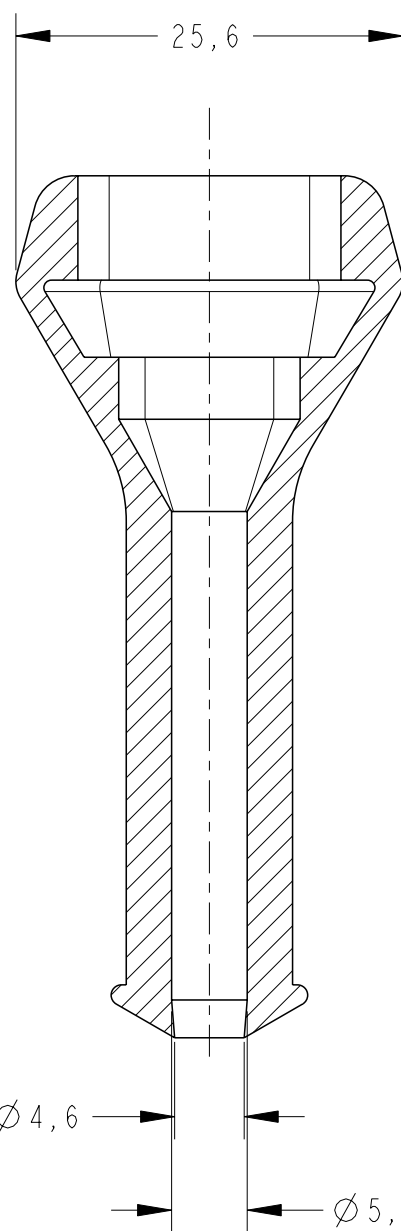
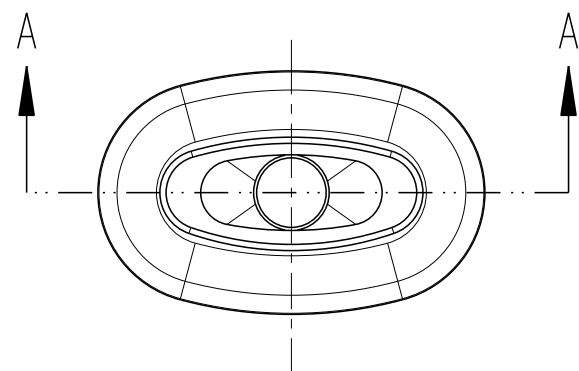

SECTION A-A

- 1 - ELASTÔMERO SAE J200, 2BC 414, A14, B14, C12, E014, F17, Z1
Z1=RESISTÊNCIA RASGO, ASTM D624 - 20kg/cm MIN.
- 2 - ELASTÔMERO SAE J200, 2BC 514, A14, B14, C12, E014, F17, Z1
Z1=RESISTÊNCIA RASGO, ASTM D624 - 20kg/cm MIN.
- 3 - ELASTOMERO SAE J 200M, 2GE, 405, A19, B37, EA14, E016, E036, F19, G11, Z1 Z1 = EXTERNAMENTE LUBRIFICADO 2%

- 1 - ELASTOMER SAE J200, 2BC 414, A14, B14, C12, E014, F17, Z1
Z1= TEAR RESISTANCE, ASTM D624 -20kg/cm MIN.
- 2 - ELASTOMER SAE J200, 2BC 514, A14, B14, C12, E014, F17, Z1
Z1= TEAR RESISTANCE, ASTM D624 -20kg/cm MIN.
- 3 - ELASTOMER SAE J 200M, 2GE, 405, A19, B37, EA14, E016, E036, F19, G11, Z1 Z1 = 2% LUBRIFICATED EXTERNALY

PRETO/BLACK	40±5 SHORE A	SILICON 3	880811-3
PRETO/BLACK	40±5 SHORE A	ELASTOMER 1	880811-2
PRETO/BLACK	50±5 SHORE A	ELASTOMER 2	880811-1
OBSOLETE			
FINISH	HARDNESS	MATERIAL	PART NUMBER

THIS DRAWING IS A CONTROLLED DOCUMENT.		DWN M.L. OGAWA 10JUN99	TE Connectivity COVER CAP 3 POSN	
DIMENSIONS: mm		CHK P.L.FARIA 10JUN99		
TOLERANCES UNLESS OTHERWISE SPECIFIED:		APVD J.M.M. NETO 10JUN99		
0 PLC ± ACCORDING 1 PLC ± DIN ISO 2 PLC ± 3302-1 3 PLC ± CLASS M2 4 PLC ± ANGLES ± FINISH SEE TABLE		NAME		
MATERIAL SEE TABLE	FINISH SEE TABLE	PRODUCT SPEC -	APPLICATION SPEC -	RESTRICTED TO -
		WEIGHT -	SIZE A3	CAGE CODE 00779
		CUSTOMER DRAWING	DRAWING NO C-880811	SCALE 2:1
			SHEET 1	OF 1
			REV DI	