



**F4 Series
Evaluation Module
User's Guide**

Wireless made simple[®]

 **Warning:** Some customers may want Linx radio frequency (“RF”) products to control machinery or devices remotely, including machinery or devices that can cause death, bodily injuries, and/or property damage if improperly or inadvertently triggered, particularly in industrial settings or other applications implicating life-safety concerns (“Life and Property Safety Situations”).

NO OEM LINX REMOTE CONTROL OR FUNCTION MODULE SHOULD EVER BE USED IN LIFE AND PROPERTY SAFETY SITUATIONS. No OEM Linx Remote Control or Function Module should be modified for Life and Property Safety Situations. Such modification cannot provide sufficient safety and will void the product’s regulatory certification and warranty.

Customers may use our (non-Function) Modules, Antenna and Connectors as part of other systems in Life Safety Situations, but only with necessary and industry appropriate redundancies and in compliance with applicable safety standards, including without limitation, ANSI and NFPA standards. It is solely the responsibility of any Linx customer who uses one or more of these products to incorporate appropriate redundancies and safety standards for the Life and Property Safety Situation application.

Do not use this or any Linx product to trigger an action directly from the data line or RSSI lines without a protocol or encoder/decoder to validate the data. Without validation, any signal from another unrelated transmitter in the environment received by the module could inadvertently trigger the action.

All RF products are susceptible to RF interference that can prevent communication. RF products without frequency agility or hopping implemented are more subject to interference. This module does not have a frequency hopping protocol built in.

Do not use any Linx product over the limits in this data guide. Excessive voltage or extended operation at the maximum voltage could cause product failure. Exceeding the reflow temperature profile could cause product failure which is not immediately evident.

Do not make any physical or electrical modifications to any Linx product. This will void the warranty and regulatory and UL certifications and may cause product failure which is not immediately evident.

Table of Contents

- 1 [Description](#)
- 2 [Ordering Information](#)
- 2 [Electrical Specifications](#)
- 3 [Pin Assignments](#)
- 3 [Pin Descriptions](#)
- 4 [Schematic](#)
- 5 [PCB Layout](#)
- 5 [Power Supply Requirements](#)

F4 Series GPS Receiver Evaluation Module User's Guide

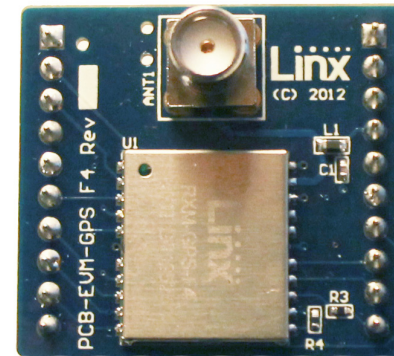

Figure 1: F4 Series Evaluation Module

Description

The F4 Series GPS receiver module is a self-contained high-performance GPS receiver with an on-board LNA and SAW filter. Based on the SiRFstar IV chipset, it provides exceptional sensitivity, even in dense foliage and urban canyons. The module's very low power consumption helps maximize runtimes in battery powered applications. With over 200,000 effective correlators, the F4 Series receiver can acquire and track up to 48 satellites simultaneously in just seconds, even at the lowest signal levels. These features, along with the module's standard NMEA data output, make it easy to integrate, even by engineers without previous RF or GPS experience. The Linx F4 Series GPS modules offer a simple, efficient and cost-effective method of adding GPS capabilities to any product.

The evaluation module contains the surface mount F4 Series GPS module, an SMA connector, a 1.8V regulator, voltage level shifters (voltage level protection for RXM and TXM lines), a microcontroller (performs F4 power up sequence), a power source switch (switches to VBACKUP when VCC is removed) and a ferrite bead (used to supply power to an external active antenna, such as the Linx SH Series active GPS antenna), all on a single board with through-hole headers. This small board makes prototyping with the F4 Series module very easy.

Ordering Information

Ordering Information	
Part Number	Description
EVM-GPS-F4	F4 Series Evaluation Module
RXM-GPS-F4	F4 Series GPS Receiver Module

Figure 2: Ordering Information

Electrical Specifications

Ordering Information						
Parameter	Designation	Min.	Typ.	Max.	Units	Notes
POWER SUPPLY						
Supply Voltage	V_{CC}	2.5	3.3	6	VDC	
Input Pin Voltage			3.6		VDC	
Output Pin Voltage			1.8		VDC	
Supply Current	I_{CC}					
Peak				130	mA	1
Acquisition			46		mA	1
Tracking			27.5		mA	1
Hibernate			20		μ A	2
Ready-to-Start			9		μ A	2
ANTENNA PORT						
RF Input Impedance	R_{IN}		50		Ω	
ENVIRONMENTAL						
Operating Temperature Range		-30		+85	$^{\circ}$ C	
Storage Temperature Range		-40		+85	$^{\circ}$ C	
Notes:						
1. $V_{CC} = 1.8V$						
2. Initial state after power us applied						

Figure 3: Electrical Specifications

Warning: This product incorporates numerous static-sensitive components. Always wear an ESD wrist strap and observe proper ESD handling procedures when working with this device. Failure to observe this precaution may result in module damage or failure.

Pin Assignments

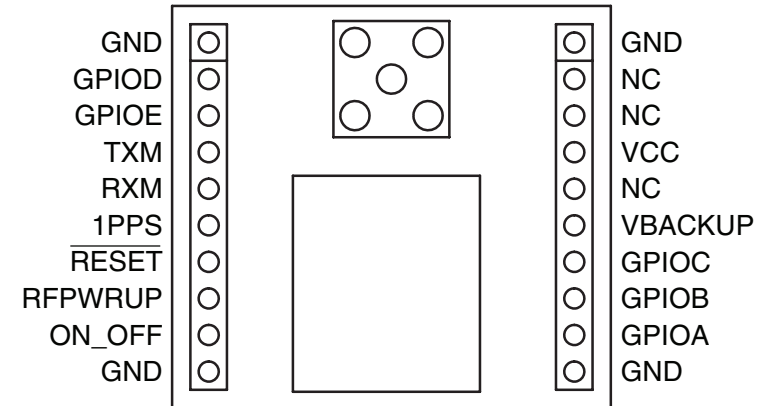

Figure 4: EVM-GPS-F4 Pin Assignments

Pin Descriptions

Pin Descriptions			
Pin Number	Name	I/O	Description
1	GPIOD	I/O	General Purpose I/O. 3.6V tolerant.
2	GPIOE	I/O	General Purpose I/O. 3.6V tolerant.
3	1PPS	O	1 Pulse Per Second. 1.8V level.
4	TX	O	Serial output (default NMEA)
5	RX	I	Serial input (default NMEA). 3.6V tolerant.
6	GPIOC	I/O	General Purpose I/O. 3.6V tolerant.
7, 11	P1, P2	I	Pull to 1.8V VCC through 2.2k resistors.
8	/RESET	I	Reset Input. Active low with an internal pull-up. Internal reset is preferred; external reset will clear all RAM. 3.6V tolerant.
9	RFPWRUP	O	Power State Indicator
10	ON_OFF	I	Power Control Pin. Internal 10k pull-down resistor. 3.6V tolerant.
12	VCC	P	Supply Voltage
13	G1	I	Pull to GND through a 100k resistor.
14	GPIOA	I/O	General Purpose I/O. 3.6V tolerant.
15	GPIOB	I/O	General Purpose I/O. 3.6V tolerant.
16, 17	NC	-	No electrical connection.
18, 20, 21, 22	GND	P	Ground
19	RFIN	I	GPS RF signal input

Figure 5: F4 Series GPS Receiver Pin Descriptions

Schematic

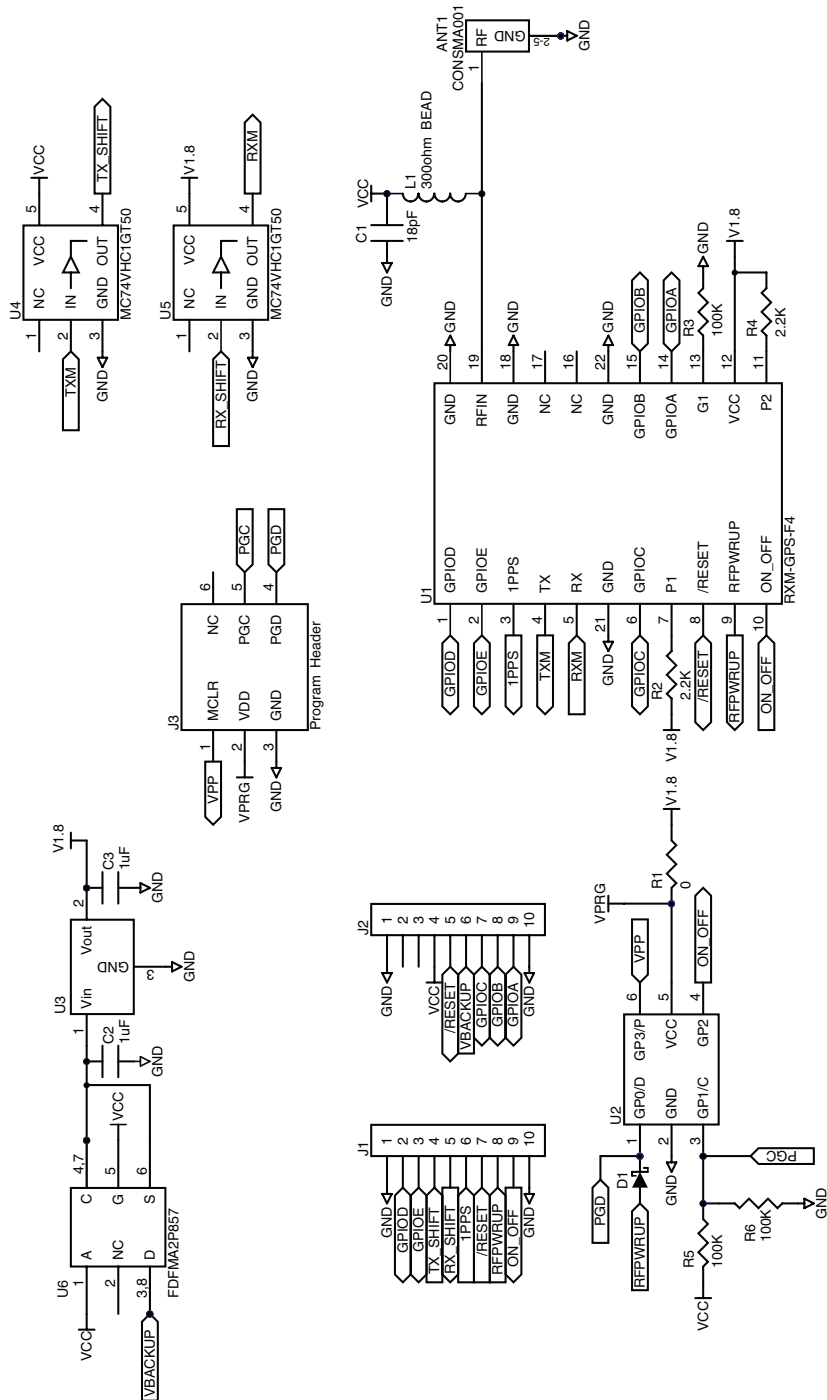

PCB Layout

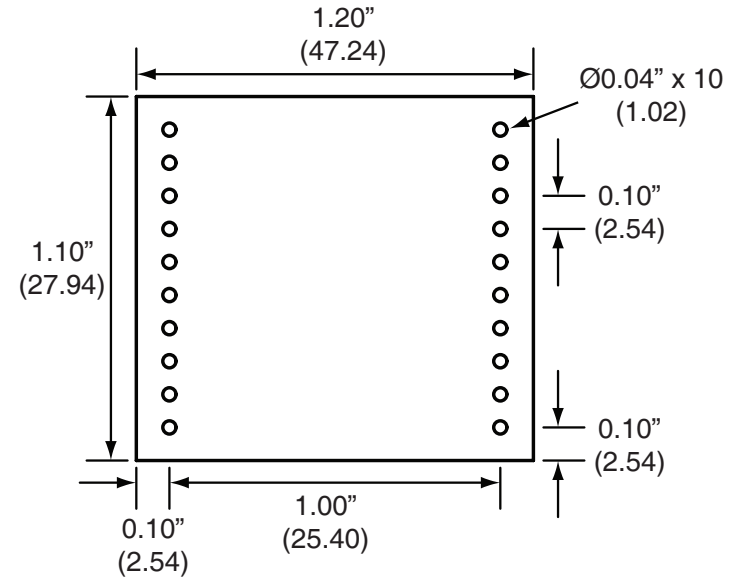

Figure 6: EVM-GPS-F4 PCB Layout Dimensions

Power Supply Requirements

The transceiver incorporates a precision low-dropout regulator which allows operation over a wide input voltage range. Despite this regulator, it is still important to provide a supply that is free of noise. Power supply noise can significantly affect the module's performance, so providing a clean power supply for the module should be a high priority during design.

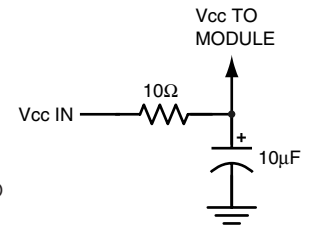

Figure 7: Supply Filter

A 10Ω resistor in series with the supply followed by a 10μF tantalum capacitor from V_{cc} to ground helps in cases where the quality of supply power is poor (Figure 7). This filter should be placed close to the module's supply lines. These values may need to be adjusted depending on the noise present on the supply line.

(This page is intentionally blank.)

(This page is intentionally blank.)



LinX Technologies
159 Ort Lane
Merlin, OR, US 97532

Phone: +1 541 471 6256
Fax: +1 541 471 6251

www.linxtechnologies.com

Disclaimer

LinX Technologies is continually striving to improve the quality and function of its products. For this reason, we reserve the right to make changes to our products without notice. The information contained in this Data Guide is believed to be accurate as of the time of publication. Specifications are based on representative lot samples. Values may vary from lot-to-lot and are not guaranteed. "Typical" parameters can and do vary over lots and application. LinX Technologies makes no guarantee, warranty, or representation regarding the suitability of any product for use in any specific application. It is the customer's responsibility to verify the suitability of the part for the intended application. **NO LINX PRODUCT IS INTENDED FOR USE IN ANY APPLICATION WHERE THE SAFETY OF LIFE OR PROPERTY IS AT RISK.**

LinX Technologies **DISCLAIMS ALL WARRANTIES OF MERCHANTABILITY AND FITNESS FOR A PARTICULAR PURPOSE. IN NO EVENT SHALL LINX TECHNOLOGIES BE LIABLE FOR ANY OF CUSTOMER'S INCIDENTAL OR CONSEQUENTIAL DAMAGES ARISING IN ANY WAY FROM ANY DEFECTIVE OR NON-CONFORMING PRODUCTS OR FOR ANY OTHER BREACH OF CONTRACT BY LINX TECHNOLOGIES.** The limitations on LinX Technologies' liability are applicable to any and all claims or theories of recovery asserted by Customer, including, without limitation, breach of contract, breach of warranty, strict liability, or negligence. Customer assumes all liability (including, without limitation, liability for injury to person or property, economic loss, or business interruption) for all claims, including claims from third parties, arising from the use of the Products. The Customer will indemnify, defend, protect, and hold harmless LinX Technologies and its officers, employees, subsidiaries, affiliates, distributors, and representatives from and against all claims, damages, actions, suits, proceedings, demands, assessments, adjustments, costs, and expenses incurred by LinX Technologies as a result of or arising from any Products sold by LinX Technologies to Customer. Under no conditions will LinX Technologies be responsible for losses arising from the use or failure of the device in any application, other than the repair, replacement, or refund limited to the original product purchase price. Devices described in this publication may contain proprietary, patented, or copyrighted techniques, components, or materials. Under no circumstances shall any user be conveyed any license or right to the use or ownership of such items.

©2016 LinX Technologies. All rights reserved.

The stylized LinX logo, Wireless Made Simple, WISE, CipherLinX and the stylized CL logo are trademarks of LinX Technologies.