

DRAWING MADE IN THIRD ANGLE PROJECTION
 THIS DRAWING IS UNPUBLISHED. RELEASED FOR PUBLICATION , 19 .
 © COPYRIGHT 19 BY AMP INCORPORATED. ALL INTERNATIONAL RIGHTS RESERVED.

| LOC | DIST | P | F | ZONE | LTR | REVISIONS | DATE | APPD |
|-----|------|---|---|------|-----|---------------------------|-----------|-------|
| AF | 50 | | | | B | RELEASED PER 0710-0619-94 | 18/JAN/95 | RG/NN |

- CONTINUOUS STRIP ON REELS WITH TERMINALS LOCATED ON 5.59 ± 0.08 [$.220 \pm .003$] CENTERS.
- SLOT TERMINATES A SINGLE MAGNET WIRE ONLY. COPPER RANGE: 0.64-0.81mm [#22-#20] AWG.
- AFTER INSERTION INTO PLASTIC HOLDER TAB PORTION MUST BE BENT OVER 45° TO 90° OR POTTED-IN TO PREVENT PULL-OUT WHEN MATING RECEPTACLE IS DISCONNECTED.

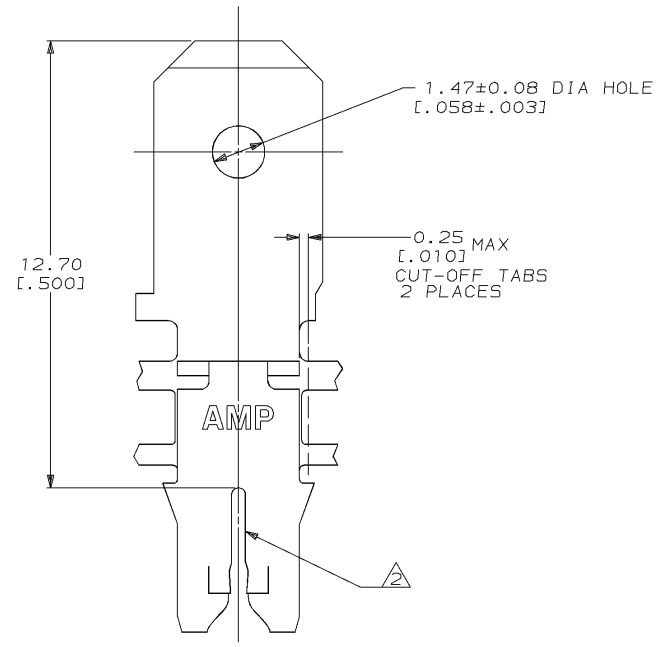
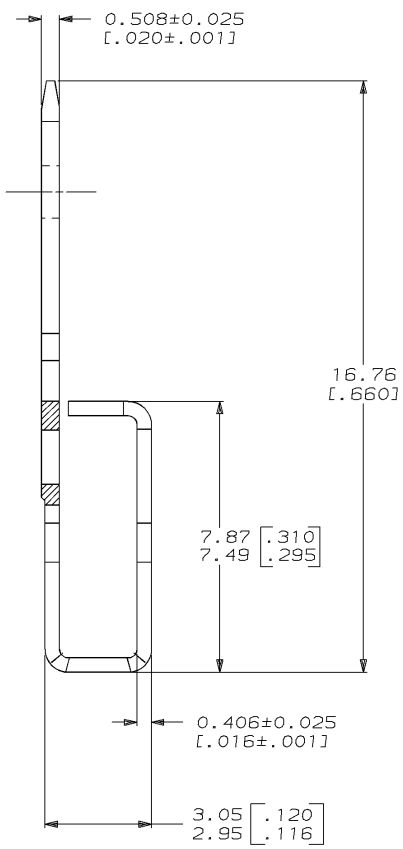
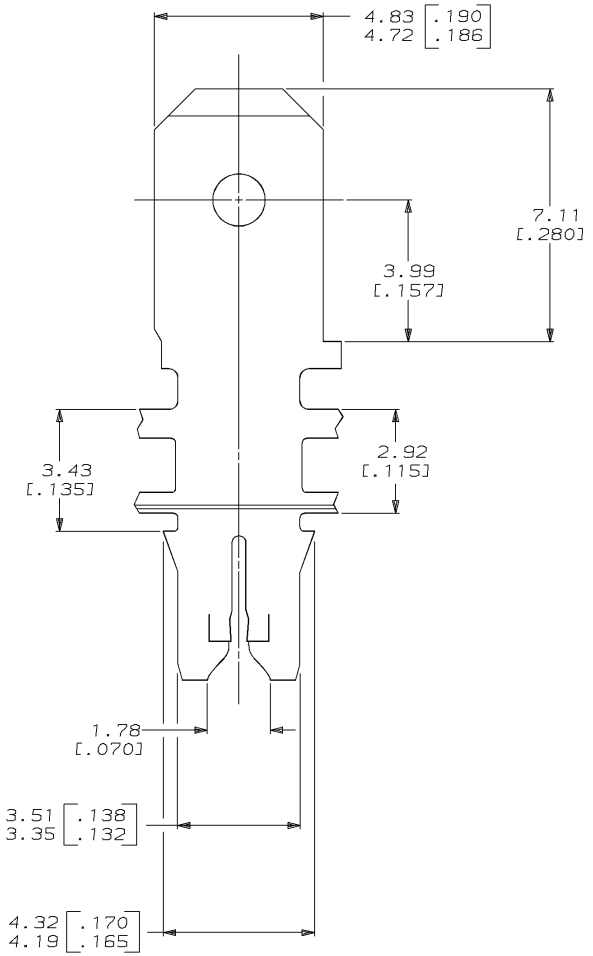
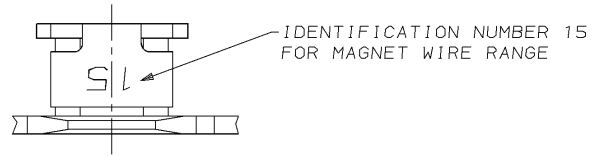

63815-1
PART NO

| | | | | |
|---|-------------------------------------|---|--------------------|-----------------------|
| DO NOT SCALE PRINT. UNLESS SPECIFIED DIMENSIONS IN mm [INCHES] TOLERANCES ON: 2 PLC DEC ± 0.25 [.010] 3 PLC DEC ± - ANGLES ± - | DR 15/OCT/94 MICHAEL S. FEHER | AMP Incorporated Harrisburg, PA 17105-3608 | | |
| MATERIAL 4M PRE-MILLED BRASS | CHK 17/OCT/94 PHILLIP M. FORTNEY | | | |
| FINISH 0.002032 [.000080] MIN TIN PER MIL-T-10727 | APPD 17/OCT/94 NELSON E. NEFF | SIZE C 00779 | CAGE CODE 00779 | DRAWING NO C-63815 |
| | APPD 17/OCT/94 TERRY L. SHUTTER | SCALE 10:1 | SHEET 1 OF 1 | |
| | PRODUCT SPEC 108-2012 | CUSTOMER DRAWING | | |
| | APPLICATION SPEC 114-2046 | | | |
| | WEIGHT | | | |

THIS DRAWING IS A CONTROLLED DOCUMENT FOR AMP INCORPORATED. IT IS SUBJECT TO CHANGE AND THE CONTROLLING ENGINEERING ORGANIZATION SHOULD BE CONTACTED FOR THE LATEST REVISION.