

2009/02/11 01:54:52 CAROL, TRIBBLE

DRAWING FOR REFERENCE: This is subject to change without notice

| COUNT  | DESCRIPTION OF REVISIONS | BY  | CHKD | DATE                | COUNT  | DESCRIPTION OF REVISIONS | BY                           | CHKD                 | DATE     |
|--|--------------------------|---|------|---------------------|--|--------------------------|------------------------------|----------------------|----------|
| △  | 2                        | DIS-E-001569  | H.K  | N.M                 | 07.06.19   | △                        |                              |                      |          |
| △  |                          |   |      |                     | △  |                          |                              |                      |          |
| <b>APPLICABLE STANDARD</b>                                     |                          |   |      |                     |  |                          |                              |                      |          |
| OPERATING TEMPERATURE RANGE                                    |                          | -30°C TO 75°C   |      |                     | STORAGE TEMPERATURE RANGE  |                          | -40°C TO 85°C                |                      |          |
| RATING   | VOLTAGE                  | 5V AC   |      |                     | CURRENT  | 1A                       |                              |                      |          |
| <b>SPECIFICATIONS</b>  |                          |   |      |                     |  |                          |                              |                      |          |
| ITEM   |                          | TEST METHOD   |      |                     | REQUIREMENTS   |                          |                              | QT                   | AT       |
| <b>CONSTRUCTION</b>  |                          |   |      |                     |  |                          |                              |                      |          |
| GENERAL EXAMINATION  |                          | VISUALLY AND BY MEASURING INSTRUMENT.   |      |                     | ACCORDING TO DRAWING.  |                          |                              | ×                    | ×        |
| MARKING  |                          | CONFIRMED VISUALLY.   |      |                     |  |                          |                              | ×                    | ×        |
| <b>ELECTRIC CHARACTERISTICS</b>                                |                          |   |      |                     |  |                          |                              |                      |          |
| CONTACT RESISTANCE   |                          | 100 mA (DC OR 1000 Hz).   |      |                     |  |                          |                              | ×                    | ×        |
| CONTACT RESISTANCE MILLIVOLT LEVEL METHOD.                     |                          | 20 mV MAX, 100 mA(DC OR 1000 Hz).   |      |                     | 50 mΩ MAX.   |                          |                              | ×                    | —        |
| INSULATION RESISTANCE  |                          | 100 V DC  |      |                     | 100 MΩ MIN.  |                          |                              | ×                    | ×        |
| VOLTAGE PROOF  |                          | 100 V AC FOR 1min.  |      |                     | NO FLASHOVER OR BREAKDOWN  |                          |                              | ×                    | ×        |
| CAPASITANCE  |                          | MEASURE ADJACENT TWO CONTACTS AT 1000±10Hz AC VOLTAGE.                                    |      |                     | 2 pF MAX   |                          |                              | ×                    | —        |
| <b>MECHANICAL CHARACTERISTICS</b>                              |                          |   |      |                     |  |                          |                              |                      |          |
| INSERTION AND WITHDRAWAL FORCES                                |                          | MEASURED BY APPLICABLE CONNECTOR.   |      |                     | INSERTION FORCE 35 N MAX.<br>EXTRACTION FORCE 7 N MIN.   |                          |                              | ×                    | —        |
| MECHANICAL OPERATION   |                          | 5000 TIMES INSERTIONS AND EXTRACTIONS.  |      |                     | ① CONTACT RESISTANCE: 70 mΩ MAX.<br>② EXTRACTION FORCE 4 N MIN.<br>③ NO DAMAGE, CRACK AND LOOSENESS, OF PARTS. |                          |                              | ×                    | —        |
| VIBRATION  |                          | FREQUENCY 10 TO 55 Hz, SINGLE AMPLITUDE 0.75 mm AT 2 h, FOR 3 DIRECTIONS.                 |      |                     | ① NO ELECTRICAL DISCONTINUITY OF 1 μs.<br>② NO DAMAGE, CRACK AND LOOSENESS, OF PARTS.                          |                          |                              | ×                    | —        |
| RANDOM VIBRATION   |                          | FREQUENCY 50 TO 2000 Hz, AT 15 min, FOR 3 DIRECTIONS.                                     |      |                     |  |                          |                              | ×                    | —        |
| SHOCK  |                          | 490 m/s <sup>2</sup> DIRECTIONS OF PULSE 11 ms AT 3TIMES FOR 6 DIRECTION. HALF SINE WAVE. |      |                     |  |                          |                              | ×                    | —        |
| <b>ENVIRONMENTAL CHARACTERISTICS</b>                           |                          |   |      |                     |  |                          |                              |                      |          |
| THERMAL SHOCK  |                          | TEMPERATURE -55→ 20~35→ 85→ 20~35 °C<br>TIME 30 → 2~3 → 30 → 2~3 min<br>UNDER 10 CYCLES,  |      |                     | ① CONTACT RESISTANCE: 70 mΩ MAX.<br>② NO DAMAGE, CRACK AND LOOSENESS, OF PARTS.                                |                          |                              | ×                    | —        |
| HUMIDITY LIFE  |                          | TEMPERATURE -10~65 °C, HUMIDITY 90 TO 98 %, UNDER 7 CYCLES (168 h)                        |      |                     | ① INSULATION RESISTANCE: 10 MΩ MIN.(AT DRY)<br>② NO DAMAGE, CRACK AND LOOSENESS, OF PARTS.                     |                          |                              | ×                    | —        |
| CORROSION SALT MIST  |                          | EXPOSED IN 5% SALT WATER SPRAY FOR 48 h. (JIS C 5402)                                     |      |                     | ① CONTACT RESISTANCE: 70 mΩ MAX.<br>② NO HEAVY CORROSION.  |                          |                              | ×                    | —        |
| SOLDERABILITY  |                          | SOLDERED AT TEMP.245°C FOR IN IMMERSION,DURATION,2~3 S.                                   |      |                     | SOLDER SHALL COVER A MINIMUM OF 95% OF THE SURFACE BEING IMMERSED.   |                          |                              | ×                    | —        |
| REMARKS  |                          |   |      |                     | DRAWN  | DESIGNED                 | CHECKED                      | APPROVED             | RELEASED |
|  |                          |   |      |                     | M.SHIMOYAMA<br>06.07.05  | M.SHIMOYAMA<br>06.07.05  | K.ICHIKAWA<br>06.07.06       | A.SUZUKI<br>06.07.06 |          |
| Unless otherwise specified, refer to USB2.0 EIA364.            |                          |   |      |                     |  |                          |                              |                      |          |
| Note QT:Qualification Test AT:Assurance Test ×:Applicable Test |                          |   |      |                     |  |                          |                              |                      |          |
| <b>HRS</b> HIROSE ELECTRIC CO., LTD.                           |                          |   |      | SPECIFICATION SHEET |  |                          | PART NO.<br>UX60SD-MB-5S55 △ |                      |          |
| CODE NO.(OLD)  |                          | DRAWING NO.<br>ELC4-125719-00   |      |                     | CODE NO.<br>CL240-0018-1-00  |                          | 1/2                          |                      |          |

# SPECIFICATIONS

## RECOMENDED REFLOW TEMPERATURE PROFILE

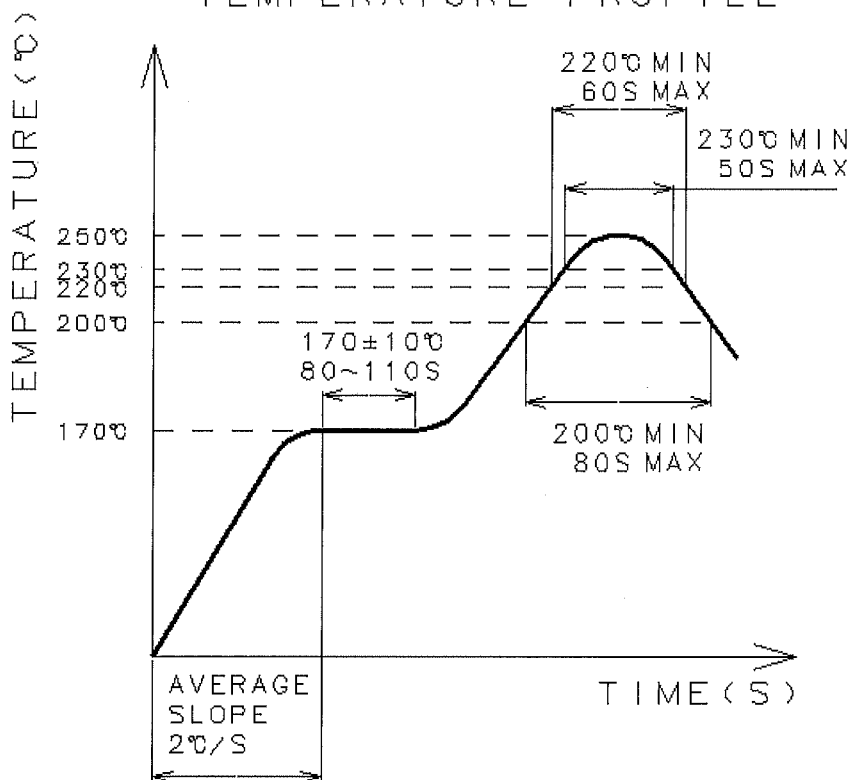

|   |                         |                         |                        |                      |          |
|---|-------------------------|-------------------------|------------------------|----------------------|----------|
| REMARKS   | DRAWN                   | DESIGNED                | CHECKED                | APPROVED             | RELEASED |
| Unless otherwise specified, refer to USB2.0 EIA364. | M.SHIMOYAMA<br>06.07.05 | M.SHIMOYAMA<br>06.07.05 | K.ICHIKAWA<br>06.07.06 | A.SUZUKI<br>06.07.06 |          |

Note QT:Qualification Test AT:Assurance Test X:Applicable Test

|                                      |                     |                            |
|--------------------------------------|---------------------|----------------------------|
| <b>HRS</b> HIROSE ELECTRIC CO., LTD. | SPECIFICATION SHEET | PART NO.<br>UX60SD-MB-5S55 |
|--------------------------------------|---------------------|----------------------------|

|               |                               |                             |        |
|---------------|-------------------------------|-----------------------------|--------|
| CODE NO.(OLD) | DRAWING NO.<br>ELC4-125719-00 | CODE NO.<br>CL240-0018-1-00 | 2<br>2 |
|---------------|-------------------------------|-----------------------------|--------|

| COUNT | DESCRIPTION OF REVISIONS | BY  | CHKD | DATE     | COUNT | DESCRIPTION OF REVISIONS | BY | CHKD | DATE |
|-------|--------------------------|-----|------|----------|-------|--------------------------|----|------|------|
| 1     | DIS-E-001569             | H.K | N.M  | 07.06.19 |       |                          |    |      |      |
| 6     | DIS-E-001871             | H.K | N.M  | 07.11.20 |       |                          |    |      |      |

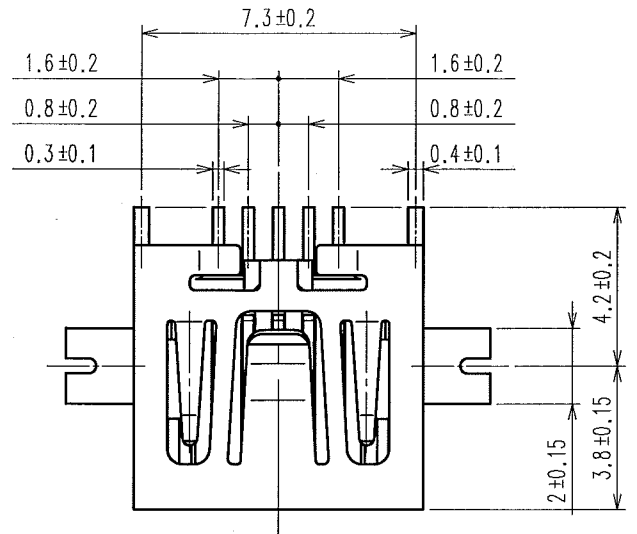

RECOMMENDED CLEARANCE AREA      RECOMMENDED PCB PATTERN

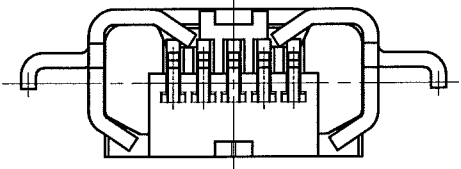
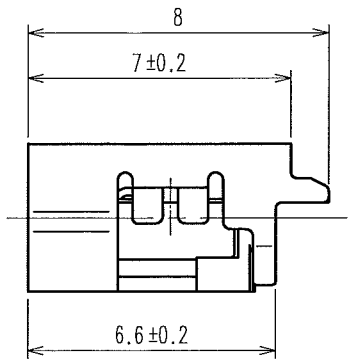
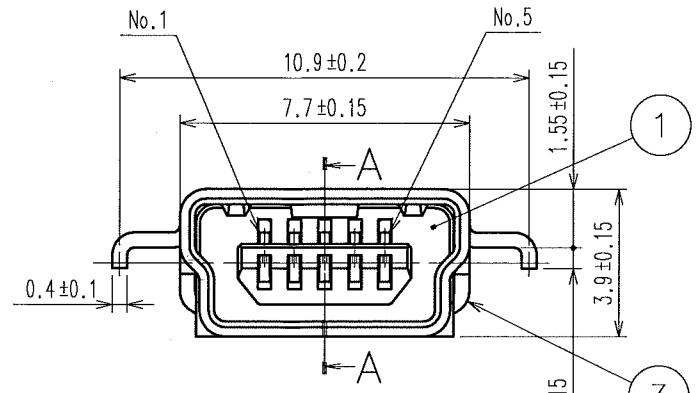
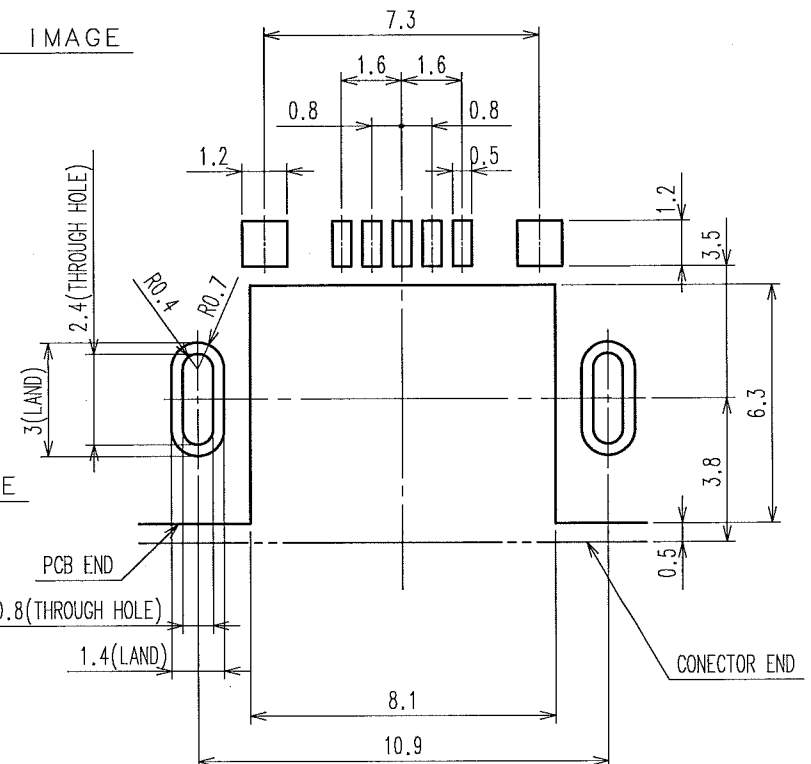
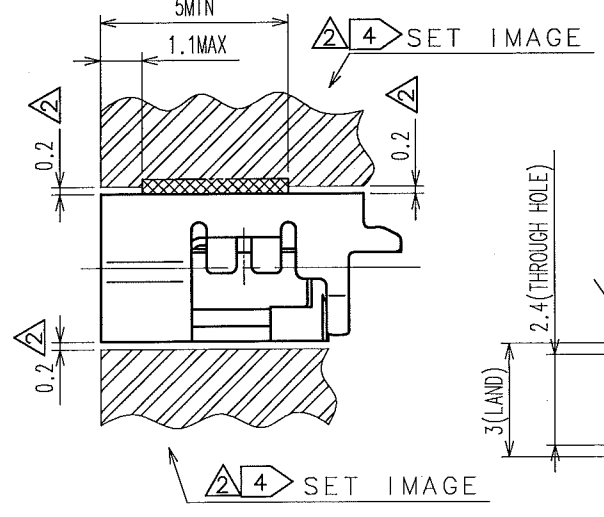
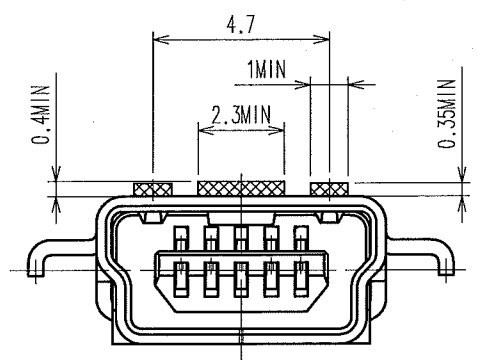

A-A

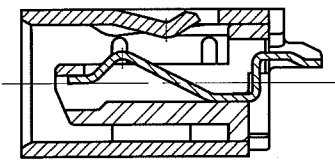

MOUNTING FIGURE

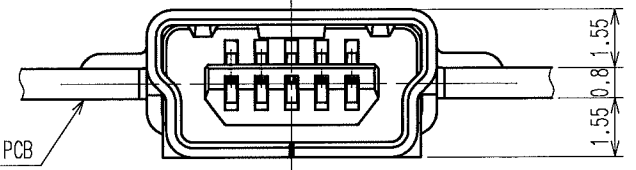

PICK & PLACE TAPE POSITION (4:1)

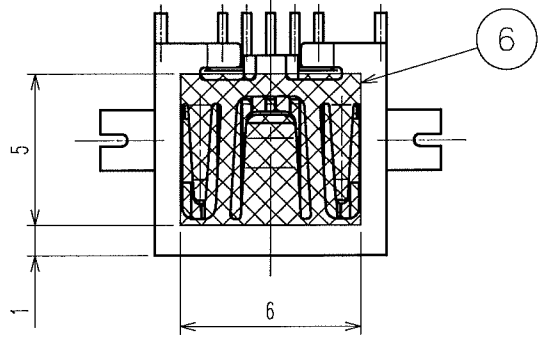

NOTE 1. INTERFACE DIMENSIONS CONFORM TO USB2.0 STANDARDS.  
 2. PER REL: 1000 PIECES.  
 3. CONTACT & METAL SHELL IS CO-PLANARITY TO BE 0.1mm MAX.  
 4. THE SET CONSTRUCTION MUST BE HOLD THE CONNECTOR'S TOP AND BOTTOM FOR PREVENTING WRENCHING FORCE.

UNREELING DIRECTION

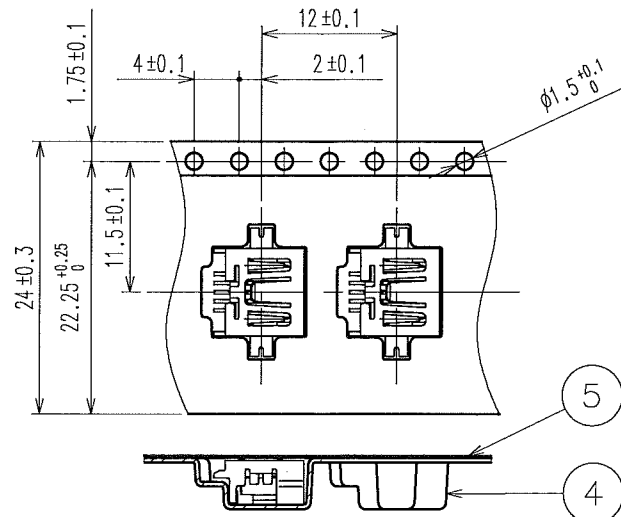

DRAWING FOR PACKING (FREE)

UNREELING DIRECTION

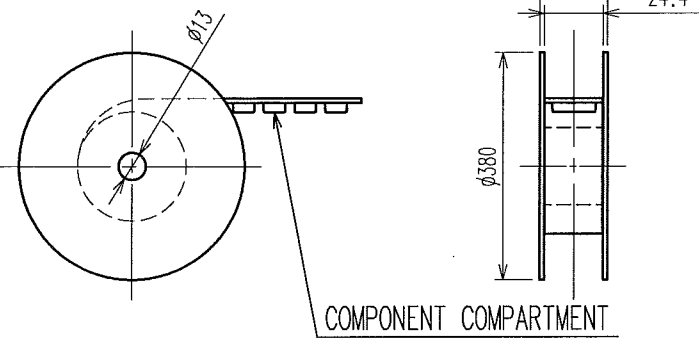

| 2   | PHOSPHOR BRONZE | UNDER PLATING: NICKEL 2μm MIN<br>CONTACT AREA: GOLD 0.75μm MIN<br>LEAD AREA: GOLD 0.03μm MIN | 6   | PICK & PLACE TAPE |   |
|-----|-----------------|--|-----|-------------------|---|
| 1   | POLYAMIDE       | UL94V-0 (BLACK)  | 5   | PS                |   |
|     |                 |  | 4   | PS                |   |
|     |                 |  | 3   | PHOSPHOR BRONZE   | UNDER PLATING: NICKEL 1μm MIN<br>MOUNTING AREA: TIN 1μm MIN |
| NO. | MATERIAL        | FINISH, REMARKS  | NO. | MATERIAL          | FINISH, REMARKS   |

|                |  |                          |             |            |          |          |
|----------------|--|--------------------------|-------------|------------|----------|----------|
| CODE NO. (OLD) |  | DRAWN                    | DESIGNED    | CHECKED    | APPROVED | RELEASED |
|                |  | M.SHIMOYAMA              | M.SHIMOYAMA | K.ICHIKAWA | A.SUZUKI |          |
|                |  | 06.07.06                 | 06.07.06    | 06.07.06   | 06.07.06 |          |
| DRAWING NO.    |  | PART NO.                 |             |            |          |          |
| EDC3-125719-00 |  | UX60SD-MB-5S55           |             |            |          |          |
| SCALE          |  | CODE NO.                 |             |            |          |          |
| 5 : 1          |  | CL240-0018-1-00          |             |            |          |          |
| UNITS          |  | HIROSE ELECTRIC CO., LTD |             |            |          |          |
| mm             |  |                          |             |            |          |          |

|    |
|----|
| TO |
|    |
|    |