

THIS DRAWING IS UNPUBLISHED. RELEASED FOR PUBLICATION
 (C) COPYRIGHT ALL RIGHTS RESERVED.

REVISIONS						
P	F	ZONE	LTR	DESCRIPTION	DATE	APPROVED
			M2	REVISED PER ECO-11-005140	31MAR11	HMR

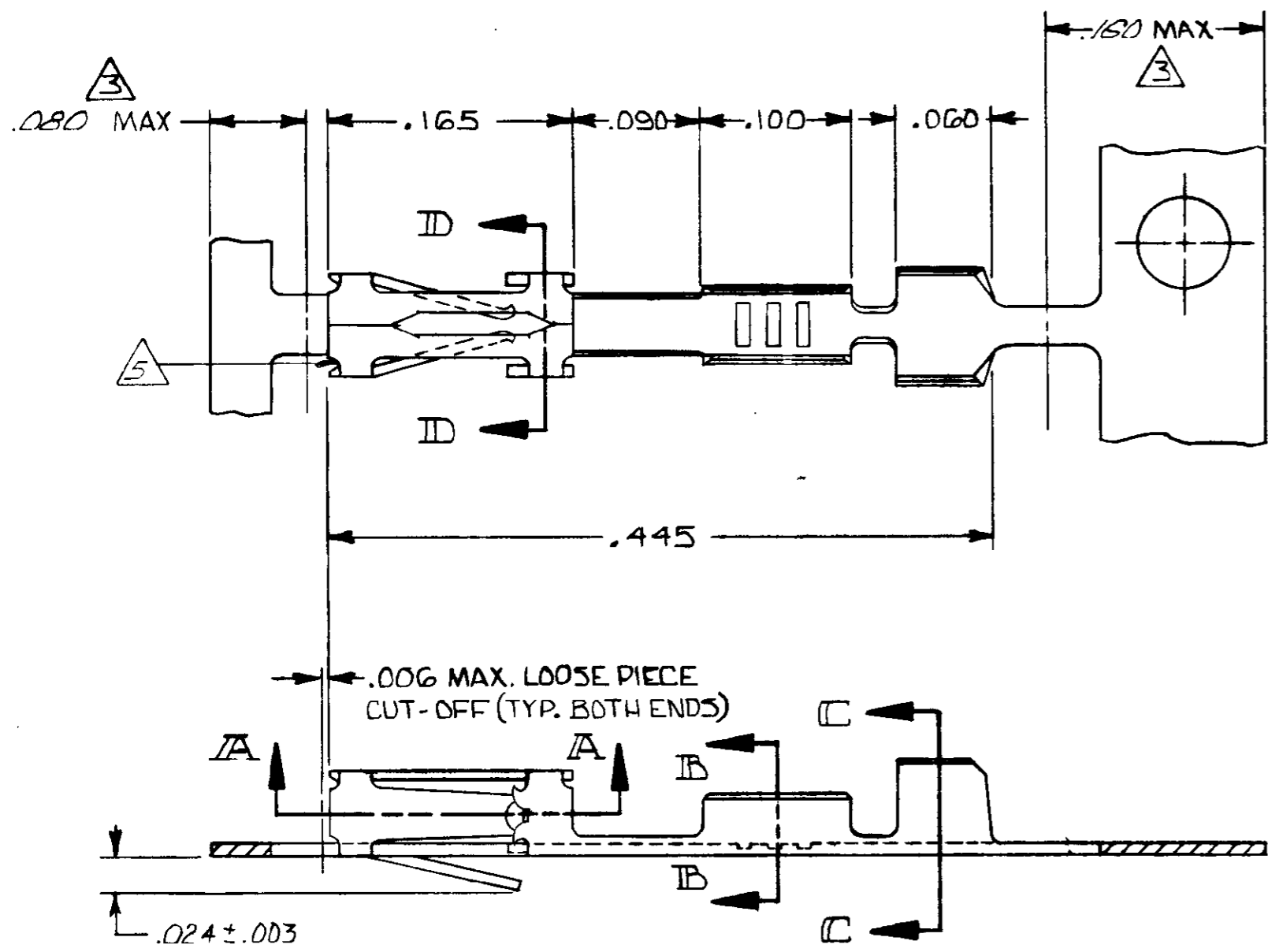

- 1 .00030 GOLD ON CONTACT AREA, GOLD FLASH ON REMAINDER, OVER .000050 NICKEL.
- 2 .00015 GOLD ON CONTACT AREA, GOLD FLASH ON THE REMAINDER, OVER .000050 NICKEL.
- 3 GOLD PLATING NOT REQUIRED IN THIS AREA.
- 4 .000100-.000200 BRIGHT TIN OVER .000030 NICKEL.
- 5 CUT OUTS ON BOX AT MANUFACTURER'S OPTION.
- 6 .000050 GOLD ON CONTACT AREA, GOLD FLASH ON THE REMAINDER, OVER .000050 NICKEL.
- 7 .000015 GOLD ON CONTACT AREA, .000050 NICKEL OVER THE ENTIRE TERMINAL.
- 8 POINT OF MEASUREMENT FOR PLATING THICKNESS (INSIDE BEAMS).
- 9 OBSOLETE PART NUMBER.
- 10 SUPERSEDED BY 102917-2.
- 11 OBSOLETE PARTS: OBSOLETE CIS STREAMLINING PER D.RENAUD/D.SINISI

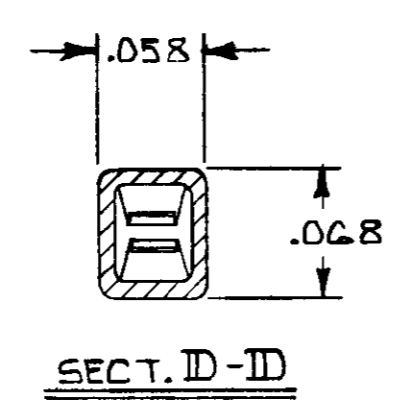
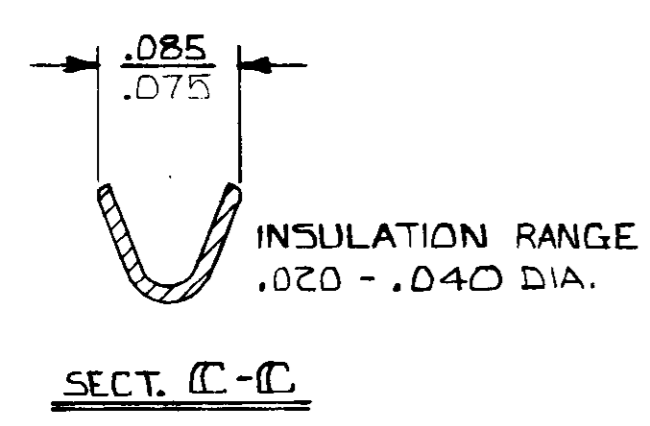
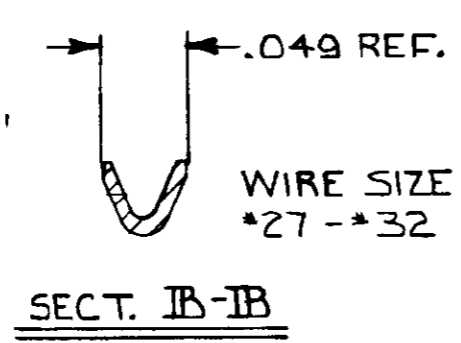
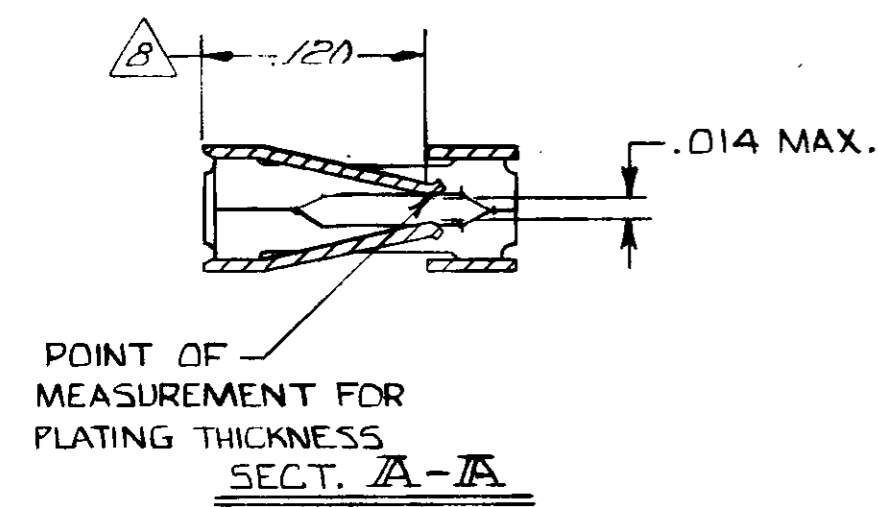

OBSOLETE	1-102917-4	1-102917-3
OBSOLETE	1-102917-2	1-102917-1
	102917-6	102917-5
OBSOLETE	102917-4	102917-3
	102917-2	102917-1
LOOSE PIECE PART NO.	FINISH	PART NO

UNLESS OTHERWISE SPECIFIED DIMENSIONS ARE IN INCHES. TOLERANCES ON: DECIMALS ± .005 ANGLES	CONTRACT NO	TE Connectivity NAME CONTACT, FEMALE, MOD IV, CRIMP SNAP-IN	
	MATERIAL BERYLLIUM COPPER .008 THK.		
FINISH SEE TABLE	CHR K. Chiba 3/25/82	SIZE C	FSCM NO 00779
	APPD M. Yungert 3/26/82	DSGN APPD	DRAWING NO 102917
	OTHER APPD	SCALE	SHEET 1 OF 1

102917