

## Quad channel high side driver

Datasheet - production data

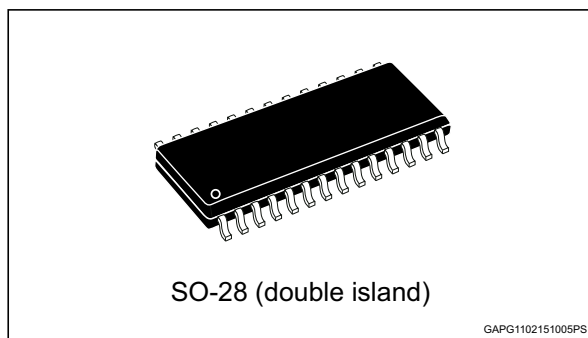

- Current limitation
- Very low standby power dissipation
- Protection against:
  - Loss of ground & loss of  $V_{CC}$
- Reverse battery protection
- In compliance with the 2002/95/EC european directive

### Description

The VNQ600P-E is a quad HSD formed by assembling two VNQ600P-E chips in the same SO-28 package. The VNQ600P-E is a monolithic device designed in STMicroelectronics VIPower M0-3 Technology. The VNQ600P-E is intended for driving any type of multiple loads with one side connected to ground.

This device has four independent channels and four analog sense outputs which deliver currents proportional to the outputs currents.

Active current limitation combined with thermal shutdown and automatic restart protect the device against overload. Device automatically turns off in case of ground pin disconnection.

### Features

Type	$R_{DS(on)}^{(1)}$	$I_{lim}$	$V_{CC}$
VNQ600AP-E	35 m $\Omega$	25 A	36 V

1. Per each channel

- DC short circuit current: 22 A
- CMOS compatible inputs
- Proportional load current sense.
- Undervoltage & overvoltage shutdown
- Overvoltage clamp
- Thermal shutdown

Table 1. Device summary

Package	Order codes	
	Tube	Tape and reel
SO-28 (double island)	VNQ600P-E	VNQ600PTR-E

# Contents

<b>1</b>	<b>Block diagram and pin description</b>	<b>5</b>
<b>2</b>	<b>Electrical specifications</b>	<b>7</b>
2.1	Absolute maximum ratings	7
2.2	Thermal data	8
2.3	Electrical characteristics	8
<b>3</b>	<b>Electrical characteristics curves</b>	<b>15</b>
<b>4</b>	<b>Application information</b>	<b>17</b>
4.1	GND protection network against reverse battery	17
4.1.1	Solution 1: a resistor in the ground line (RGND only)	17
4.1.2	Solution 2: a diode ( $D_{GND}$ ) in the ground line	18
4.2	Load dump protection	18
4.3	MCU I/O protection	18
4.4	Maximum demagnetization energy ( $V_{CC} = 13.5\text{ V}$ )	19
<b>5</b>	<b>Package and PCB thermal data</b>	<b>20</b>
5.1	SO-28 thermal data	20
<b>6</b>	<b>Package information</b>	<b>23</b>
6.1	SO-28 package information	23
6.2	SO-28 packing information	25
<b>7</b>	<b>Revision history</b>	<b>26</b>

## List of tables

Table 1.	Device summary . . . . .	1
Table 2.	Suggested connections for unused and not connected pins . . . . .	6
Table 3.	Absolute maximum rating . . . . .	7
Table 4.	Thermal data (per island) . . . . .	8
Table 5.	Power . . . . .	9
Table 6.	Protections . . . . .	9
Table 7.	Switching ( $V_{CC} = 13\text{ V}$ ; $T_j = 25\text{ °C}$ ) . . . . .	10
Table 8.	Current sense ( $9\text{ V} < V_{CC} < 16\text{ V}$ ) . . . . .	10
Table 9.	Logic inputs. . . . .	11
Table 10.	$V_{CC}$ - output diode . . . . .	11
Table 11.	Truth table. . . . .	12
Table 12.	Electrical transient requirements (part 1/3) . . . . .	13
Table 13.	Electrical transient requirements (part 2/3) . . . . .	13
Table 14.	Electrical transient requirements (part 3/3) . . . . .	13
Table 15.	Thermal calculation according to the PCB heatsink area . . . . .	20
Table 16.	Thermal parameters . . . . .	22
Table 17.	SO-28 mechanical data . . . . .	23
Table 18.	Document revision history. . . . .	26

## List of figures

Figure 1.	Block diagram . . . . .	5
Figure 2.	Configuration diagram (top view) . . . . .	6
Figure 3.	Current and voltage conventions . . . . .	8
Figure 4.	IOOUT/ISENSE versus IOOUT . . . . .	11
Figure 5.	Switching characteristics . . . . .	12
Figure 6.	Waveforms . . . . .	14
Figure 7.	Off state output current . . . . .	15
Figure 8.	Low level input current . . . . .	15
Figure 9.	Input clamp voltage . . . . .	15
Figure 10.	Turn-on voltage slope . . . . .	15
Figure 11.	Overvoltage shutdown . . . . .	15
Figure 12.	Turn-off voltage slope . . . . .	15
Figure 13.	$I_{LIM}$ vs $T_{case}$ . . . . .	16
Figure 14.	Input low level . . . . .	16
Figure 15.	Input high level . . . . .	16
Figure 16.	Input hysteresis voltage . . . . .	16
Figure 17.	On state resistance vs $T_{case}$ . . . . .	16
Figure 18.	Application schematic . . . . .	17
Figure 19.	Maximum turn-off current versus load inductance . . . . .	19
Figure 20.	SO-28 PC board . . . . .	20
Figure 21.	$R_{thj-amb}$ Vs PCB copper area in open box free air condition . . . . .	21
Figure 22.	Thermal impedance junction ambient single pulse . . . . .	21
Figure 23.	Thermal fitting model of a quad channel HSD in SO-28 . . . . .	22
Figure 24.	SO-28 package outline . . . . .	23
Figure 25.	SO-28 tube shipment (no suffix) . . . . .	25
Figure 26.	SO-28 tape and reel shipment (suffix "TR") . . . . .	25

# 1 Block diagram and pin description

Figure 1. Block diagram

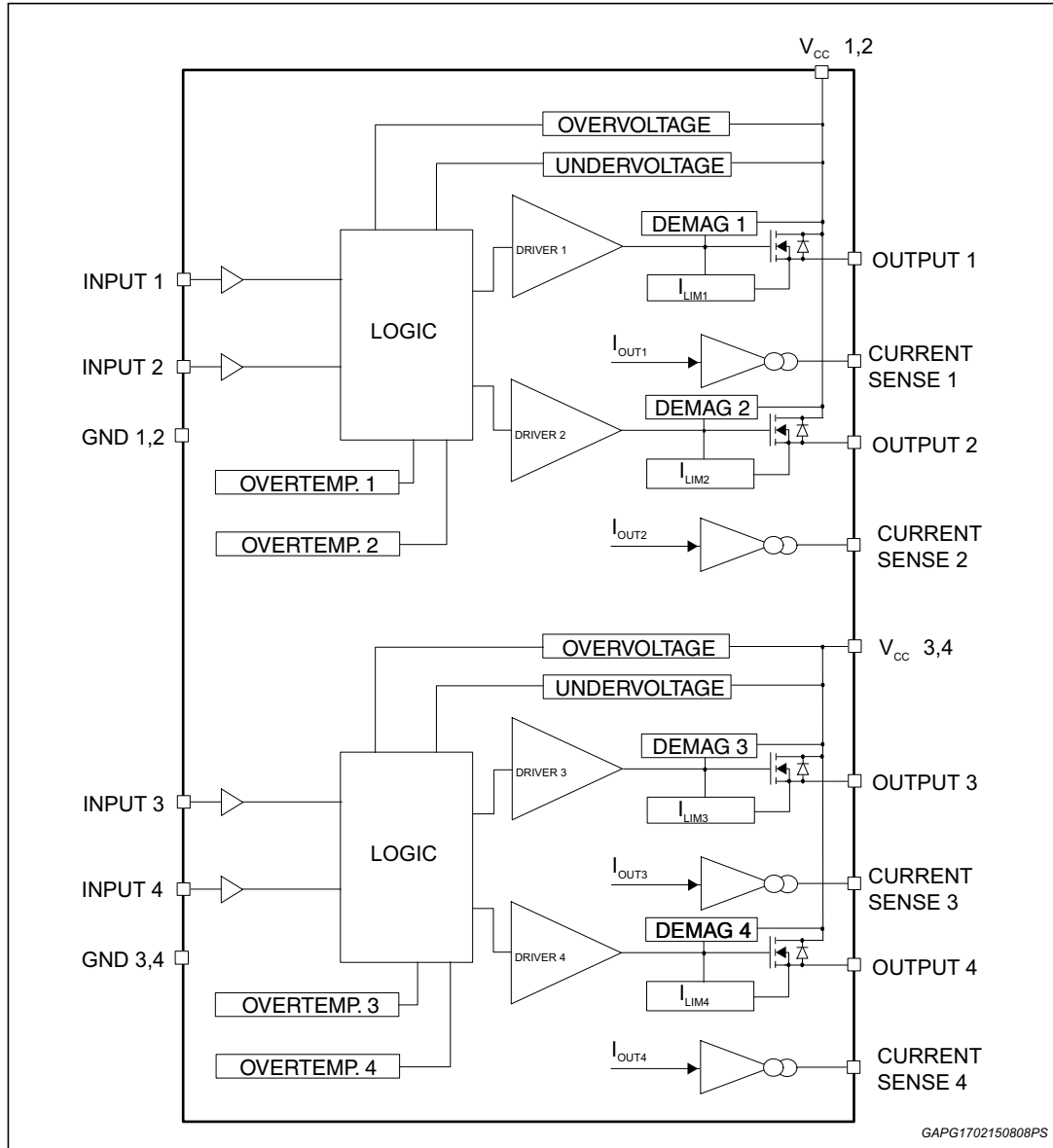

Figure 2. Configuration diagram (top view)

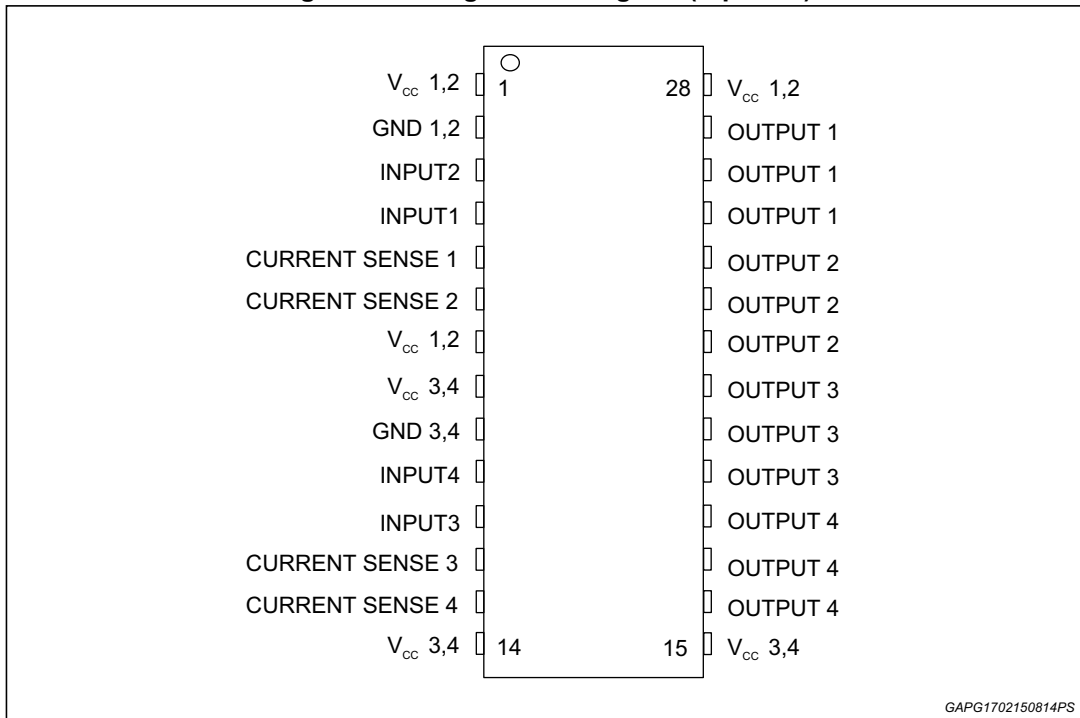

Table 2. Suggested connections for unused and not connected pins

Connection / pin	Current sense	N.C.	Output	Input
Floating		X	X	X
To ground	Through 1 KΩ resistor	X		Through 10 KΩ resistor

## 2 Electrical specifications

### 2.1 Absolute maximum ratings

Stressing the device above the rating listed in the “Absolute maximum ratings” table may cause permanent damage to the device. These are stress ratings only and operation of the device at these or any other conditions above those indicated in the Operating sections of this specification is not implied. Exposure to Absolute Maximum Rating conditions for extended periods may affect device reliability. Refer also to the STMicroelectronics SURE Program and other relevant quality document.

**Table 3. Absolute maximum rating**

Symbol	Parameter	Value	Unit
$V_{CC}$	Supply voltage (continuous)	41	V
$-V_{CC}$	Reverse supply voltage (continuous)	-0.3	V
$I_{OUT}$	Output current (continuous), for each channel	15	A
$I_R$	Reverse output current (continuous), for each channel	-15	A
$I_{IN}$	Input current	±10	mA
$V_{CSENSE}$	Current sense maximum voltage	-3 +15	V V
$I_{GND}$	Ground current at $T_{pins} \leq 25\text{ °C}$ (continuous)	-200	mA
$V_{ESD}$	Electrostatic discharge (Human Body Model: $R = 1.5\text{ k}\Omega$ ; $C = 100\text{ pF}$ )		
	– INPUT	4000	V
	– CURRENT SENSE	2000	V
	– OUTPUT	5000	V
	– $V_{CC}$	5000	V
$E_{MAX}$	Maximum switching energy ( $L = 0.11\text{ mH}$ ; $R_L = 0\ \Omega$ ; $V_{bat} = 13.5\text{ V}$ ; $T_{jstart} = 150\text{ °C}$ ; $I_L = 40\text{ A}$ )	126	mJ
$P_{tot}$	Power dissipation (per island) at $T_{lead} = 25\text{ °C}$	6.25	W
$T_j$	Junction operating temperature	Internally limited	°C
$T_{stg}$	Storage temperature	-55 to 150	°C

## 2.2 Thermal data

Table 4. Thermal data (per island)

Symbol	Parameter	Value		Unit
$R_{thj-lead}$	Thermal resistance junction-lead	15		$^{\circ}C/W$
$R_{thj-amb}$	Thermal resistance junction-ambient (one chip ON)	60 <sup>(1)</sup>	44 <sup>(2)</sup>	$^{\circ}C/W$
$R_{thj-amb}$	Thermal Resistance junction-ambient (two chips ON)	46 <sup>(1)</sup>	31 <sup>(2)</sup>	$^{\circ}C/W$

1. When mounted on a standard single-sided FR-4 board with 0.5cm<sup>2</sup> of Cu (at least 35  $\mu$ m thick) connected to all  $V_{CC}$  pins. Horizontal mounting and no artificial air flow.
2. When mounted on a standard single-sided FR-4 board with 6cm<sup>2</sup> of Cu (at least 35  $\mu$ m thick) connected to all  $V_{CC}$  pins. Horizontal mounting and no artificial air flow.

## 2.3 Electrical characteristics

Values specified in this section are for 8 V <  $V_{CC}$  < 36 V; -40  $^{\circ}C$  <  $T_j$  < 150  $^{\circ}C$ , unless otherwise stated.

Figure 3. Current and voltage conventions

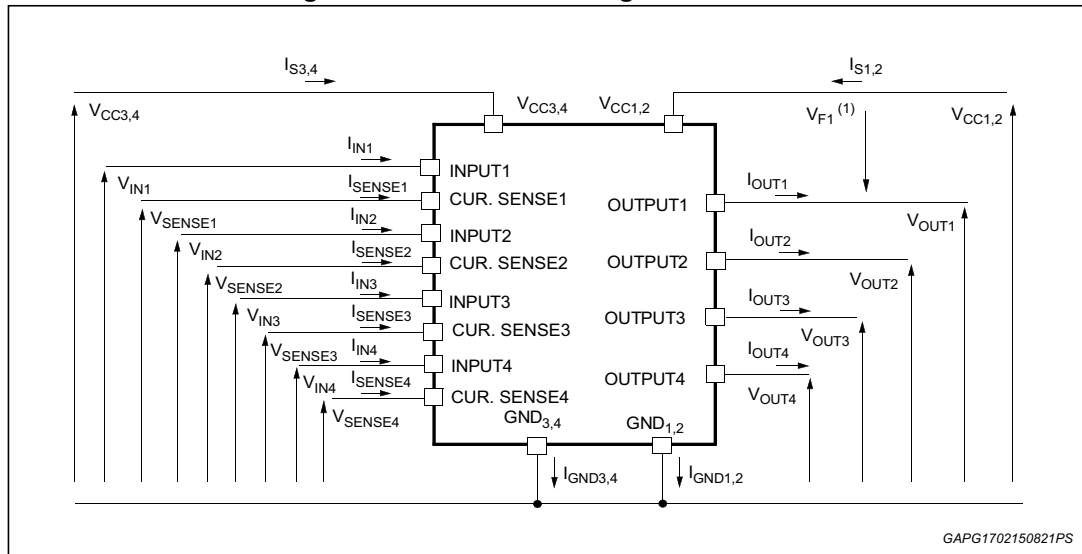

1.  $V_{Fn} = V_{CCn} - V_{OUTn}$  during reverse battery condition.



Table 5. Power

Symbol	Parameter	Test conditions	Min.	Typ.	Max.	Unit
$V_{CC}$	Operating supply voltage		5.5	13	36	V
$V_{USD}$	Undervoltage shutdown		3	4	5.5	V
$V_{OV}$	Overvoltage shutdown		36			V
$R_{ON}$	On state resistance	$I_{OUT1,2,3,4} = 5\text{ A}; T_j = 25^\circ\text{C}$ $I_{OUT1,2,3,4} = 5\text{ A}; T_j = 50^\circ\text{C}$ $I_{OUT1,2,3,4} = 3\text{ A}; V_{CC} = 6\text{ V}$			35 70 120	mΩ mΩ mΩ
$V_{clamp}$	Clamp voltage	$I_{CC} = 20\text{ mA}$	41	48	55	V
$I_S$	Supply current	Off State; $V_{CC} = 13\text{ V};$ $V_{IN} = V_{OUT} = 0\text{ V}$		12	40	μA
		Off State; $V_{CC} = 13\text{ V};$ $V_{IN}=V_{OUT}=0\text{V};$ $T_j = 25^\circ\text{C}$		12	25	μA
		On State; $V_{CC} = 13\text{ V}; V_{IN} = 5\text{V};$ $I_{OUT} = 0\text{ A}; R_{SENSE} = 3.9\text{ K}\Omega$			6	mA
$I_{L(off1)}$	Off state output current	$V_{IN} = V_{OUT} = 0\text{ V}$	0		50	μA
$I_{L(off2)}$	Off state output current	$V_{IN} = 0\text{ V}; V_{OUT} = 3.5\text{ V}$	-75		0	μA
$I_{L(off3)}$	Off state output current	$V_{IN} = V_{OUT} = 0\text{ V}; V_{CC} = 13\text{ V};$ $T_j = 125^\circ\text{C}$			5	μA
$I_{L(off4)}$	Off state output current	$V_{IN} = V_{OUT} = 0\text{ V}; V_{CC} = 13\text{ V};$ $T_j = 25^\circ\text{C}$			3	μA

Note:  $V_{clamp}$  and  $V_{OV}$  are correlated. Typical difference is 5V.

Table 6. Protections

Symbol	Parameter	Test conditions	Min.	Typ.	Max.	Unit
$I_{lim}$	DC Short circuit current	$V_{CC} = 13\text{ V}$	25	40	70	A
		$5.5\text{ V} < V_{CC} < 36\text{ V}$			70	A
$T_{TSD}$	Thermal shutdown temperature		150	175	200	°C
$T_R$	Thermal reset temperature		135			°C
$T_{hyst}$	Thermal hysteresis		7	15		°C
$V_{demag}$	Turn-off output voltage clamp	$I_{OUT} = 2\text{ A}; L = 6\text{ mH}$	$V_{CC}-41$	$V_{CC}-48$	$V_{CC}-55$	V
$V_{ON}$	Output voltage drop limitation	$I_{OUT} = 0.5\text{ A};$ $T_j = -40^\circ\text{C to } +150^\circ\text{C}$		50		mV

Note: To ensure long term reliability under heavy overload or short circuit conditions, protection and related diagnostic signals must be used together with a proper software strategy. If the device is subjected to abnormal conditions, this software must limit the duration and number of activation cycles.

**Table 7. Switching ( $V_{CC} = 13\text{ V}$ ;  $T_j = 25\text{ }^\circ\text{C}$ )**

Symbol	Parameter	Test conditions	Min.	Typ.	Max.	Unit
$t_{d(on)}$	Turn-on delay time	$R_L = 2.6\ \Omega$ channels 1,2,3,4 (see <a href="#">Figure 5</a> )		40		$\mu\text{s}$
$t_{d(off)}$	Turn-off delay time	$R_L = 2.6\ \Omega$ channels 1,2,3,4 (see <a href="#">Figure 5</a> )		40		$\mu\text{s}$
$(dV_{OUT}/dt)_{on}$	Turn-on voltage slope	$R_L = 2.6\ \Omega$ channels 1,2,3,4 (see <a href="#">Figure 5</a> )		See <a href="#">Figure 10</a>		$\text{V}/\mu\text{s}$
$(dV_{OUT}/dt)_{off}$	Turn-off voltage slope	$R_L = 2.6\ \Omega$ channels 1,2,3,4 (see <a href="#">Figure 5</a> )		See <a href="#">Figure 12</a>		$\text{V}/\mu\text{s}$

**Table 8. Current sense ( $9\text{ V} < V_{CC} < 16\text{ V}$ )**

Symbol	Parameter	Test conditions	Min.	Typ.	Max.	Unit
$K_1$	$I_{OUT}/I_{SENSE}$	$I_{OUT1}$ or $I_{OUT2} = 0.5\text{ A}$ ; $V_{SENSE} = 0.5\text{ V}$ ; other channels open; $T_j = -40\text{ }^\circ\text{C} \dots 150\text{ }^\circ\text{C}$	3300	4400	6000	
$dK_1/K_1$	Current sense ratio drift	$I_{OUT1}$ or $I_{OUT2} = 0.35\text{ A}$ ; $V_{SENSE} = 0.5\text{ V}$ ; other channels open; $T_j = -40\text{ }^\circ\text{C} \dots 150\text{ }^\circ\text{C}$	-10		+10	%
$K_2$	$I_{OUT}/I_{SENSE}$	$I_{OUT1}$ or $I_{OUT2} = 5\text{ A}$ ; $V_{SENSE} = 4\text{ V}$ ; other channels open; $T_j = -40\text{ }^\circ\text{C}$ $T_j = 25\text{ }^\circ\text{C} \dots 150\text{ }^\circ\text{C}$	4200 4400	4900 4900	6000 5750	
$dK_2/K_2$	Current sense ratio drift	$I_{OUT1}$ or $I_{OUT2} = 2\text{ A}$ ; $V_{SENSE} = 2.5\text{ V}$ ; other channels open; $T_j = -40\text{ }^\circ\text{C} \dots 150\text{ }^\circ\text{C}$	-6		+6	%
$K_3$	$I_{OUT}/I_{SENSE}$	$I_{OUT1}$ or $I_{OUT2} = 15\text{ A}$ ; $V_{SENSE} = 4\text{ V}$ ; other channels open; $T_j = -40\text{ }^\circ\text{C}$ ; $T_j = 25\text{ }^\circ\text{C} \dots 150\text{ }^\circ\text{C}$	4200 4400	4900 4900	5500 5250	
$dK_3/K_3$	Current sense ratio drift	$I_{OUT1}$ or $I_{OUT2} = 15\text{ A}$ ; $V_{SENSE} = 4\text{ V}$ ; other channels open; $T_j = -40\text{ }^\circ\text{C} \dots 150\text{ }^\circ\text{C}$	-6		+6	%
$V_{SENSE1,2}$	Max analog sense output voltage	$V_{CC} = 5.5\text{ V}$ ; $I_{OUT1,2} = 2.5\text{ A}$ ; $R_{SENSE} = 10\text{ k}\Omega$ $V_{CC} > 8\text{ V}$ , $I_{OUT1,2} = 5\text{ A}$ ; $R_{SENSE} = 10\text{ k}\Omega$	2 4			$\text{V}$ $\text{V}$
$V_{SENSEH}$	Analog sense output voltage in overtemperature condition	$V_{CC} = 13\text{ V}$ ; $R_{SENSE} = 3.9\text{ k}\Omega$		5.5		$\text{V}$

**Table 8. Current sense (9 V < V<sub>CC</sub> < 16 V) (continued)**

Symbol	Parameter	Test conditions	Min.	Typ.	Max.	Unit
R <sub>VSENSEH</sub>	Analog sense output Impedance in overtemperature condition	V <sub>CC</sub> =13V; T <sub>j</sub> >T <sub>TSD</sub> ; All channels open		400		W
t <sub>DSENSE</sub>	Current sense delay response	To 90% I <sub>SENSE</sub> <sup>(1)</sup>			500	μs

1. Current sense signal delay after positive input slope.

**Table 9. Logic inputs**

Symbol	Parameter	Test conditions	Min.	Typ.	Max.	Unit
V <sub>IL</sub>	Low level input voltage				1.25	V
V <sub>IH</sub>	High level input voltage		3.25			V
V <sub>I(hyst)</sub>	Input hysteresis voltage		0.5			V
I <sub>IL</sub>	Input current	V <sub>IN</sub> = 1.5 V	1			μA
I <sub>IN</sub>	Input current	V <sub>IN</sub> = 3.5 V			10	μA
V <sub>ICL</sub>	Input clamp voltage	I <sub>IN</sub> = 1 mA I <sub>IN</sub> = -1 mA	6	6.8 -0.7	8	V V

**Table 10. V<sub>CC</sub> - output diode**

Symbol	Parameter	Test conditions	Min.	Typ.	Max.	Unit
V <sub>F</sub>	Forward on voltage	-I <sub>OUT</sub> = 2.3 A; T <sub>j</sub> = 150 °C			0.6	V

**Figure 4. I<sub>OUT</sub>/I<sub>SENSE</sub> versus I<sub>OUT</sub>**

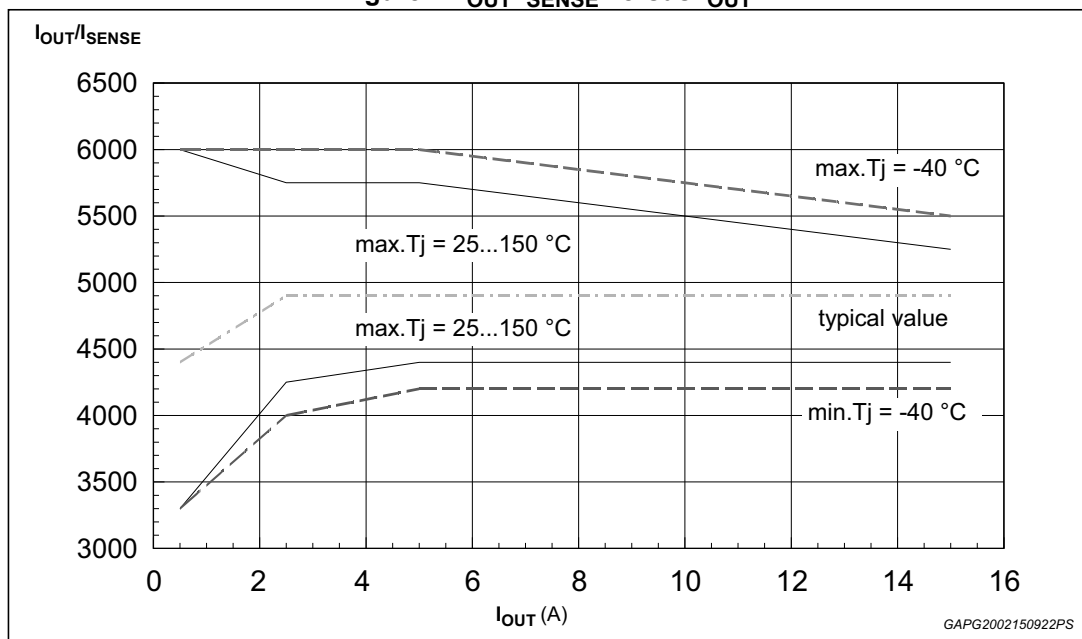

Figure 5. Switching characteristics

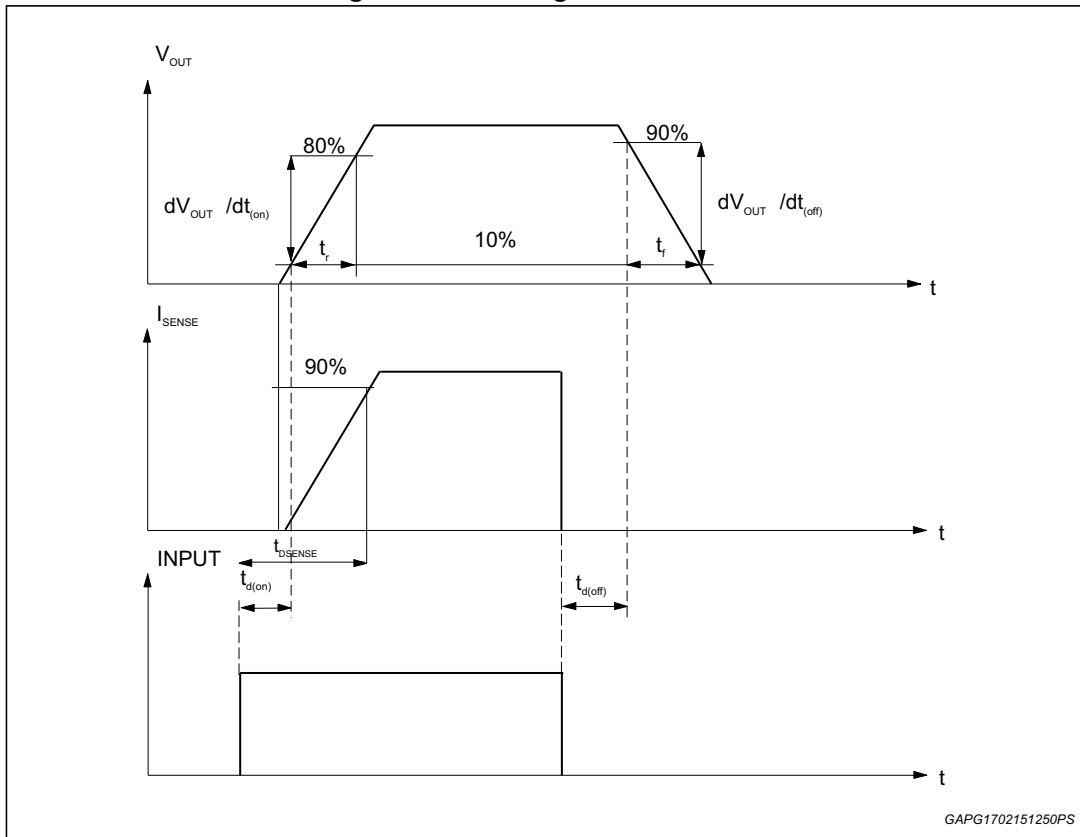

Table 11. Truth table

Conditions	Input	Output	Sense
Normal operation	L	L	0
	H	H	Nominal
Overtemperature	L	L	0
	H	L	$V_{SENSEH}$
Undervoltage	L	L	0
	H	L	0
Overvoltage	L	L	0
	H	L	0
Short circuit to GND	L	L	0
	H	L	$(T_j < T_{TSD}) 0$ $(T_j > T_{TSD}) V_{SENSEH}$
Short circuit to $V_{CC}$	L	H	0
	H	H	< Nominal
Negative output voltage clamp	L	L	0

**Table 12. Electrical transient requirements (part 1/3)**

ISO T/R 7637/1 Test pulse	Test levels I	Test levels II	Test levels III	Test levels IV	Test levels delays and impedance
1	-25 V	-50 V	-75 V	-100 V	2 ms, 10 Ω
2	+25 V	+50 V	+75 V	+100 V	0.2 ms, 10 Ω
3a	-25 V	-50 V	-100 V	-150 V	0.1 μs, 50 Ω
3b	+25 V	+50 V	+75 V	+100 V	0.1μs, 50 Ω
4	-4 V	-5 V	-6 V	-7 V	100ms, 0.01 Ω
5	+26.5 V	+46.5 V	+66.5 V	+86.5 V	400ms, 2 Ω

**Table 13. Electrical transient requirements (part 2/3)**

ISO T/R 7637/1 Test pulse	Test levels result I	Test levels result II	Test levels result III	Test levels result IV
1	C	C	C	C
2	C	C	C	C
3a	C	C	C	C
3b	C	C	C	C
4	C	C	C	C
5	C	E	E	E

**Table 14. Electrical transient requirements (part 3/3)**

Class	Contents
C	All functions of the device are performed as designed after exposure to disturbance.
E	One or more functions of the device is not performed as designed after exposure and cannot be returned to proper operation without replacing the device.

Figure 6. Waveforms

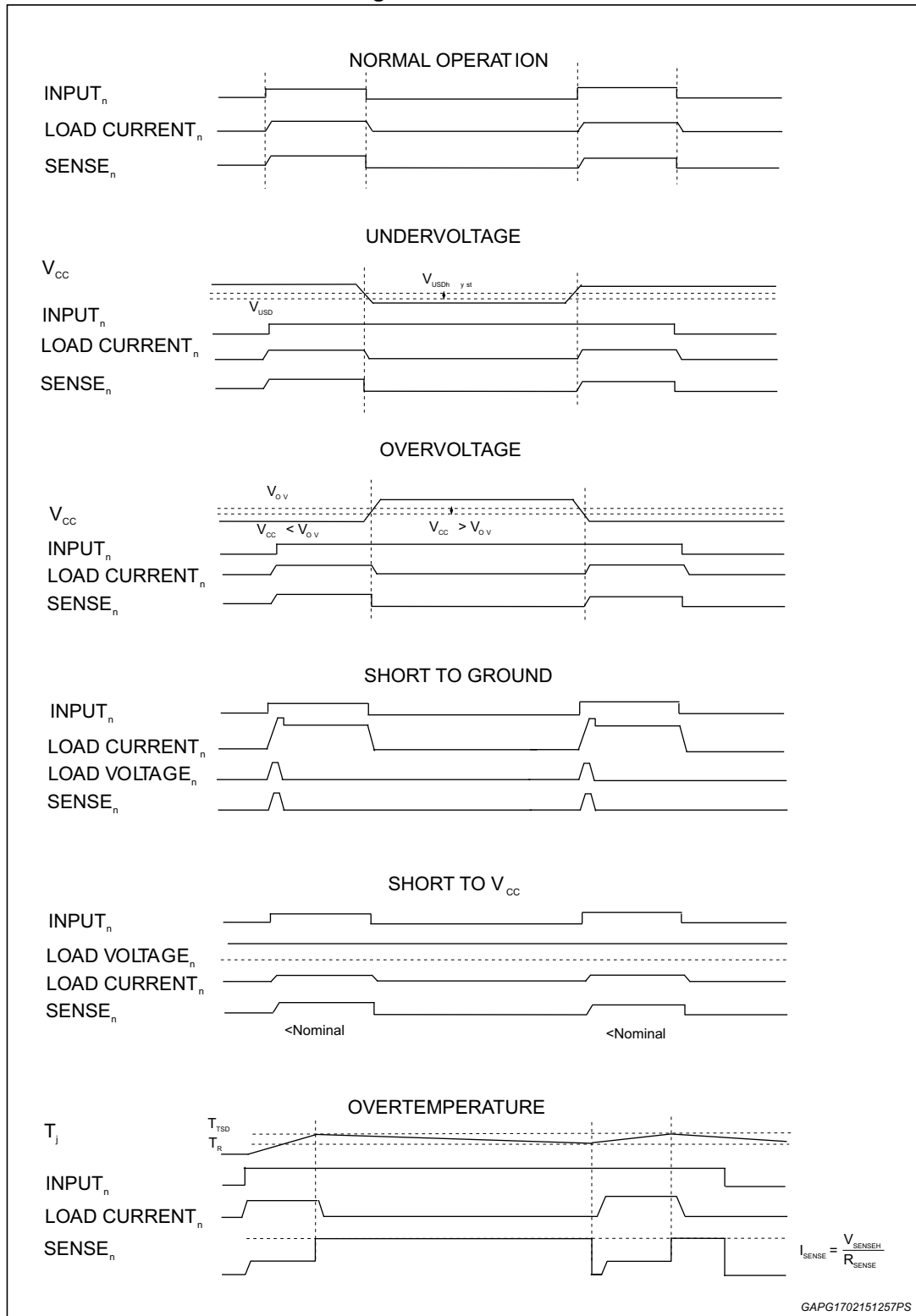

### 3 Electrical characteristics curves

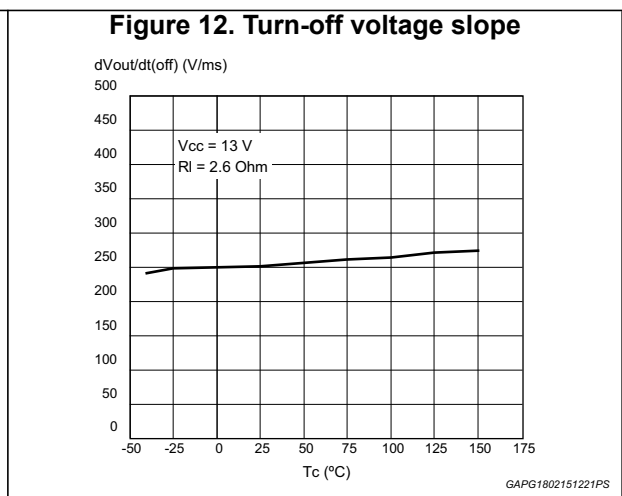
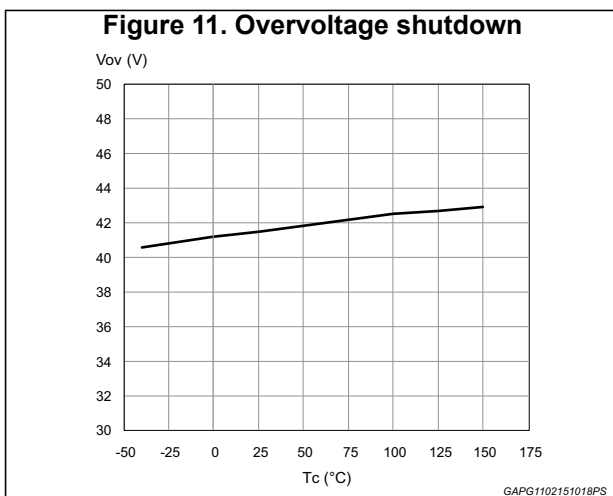
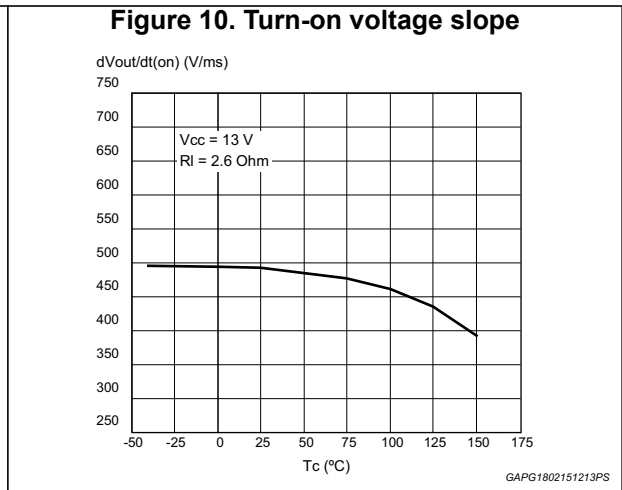
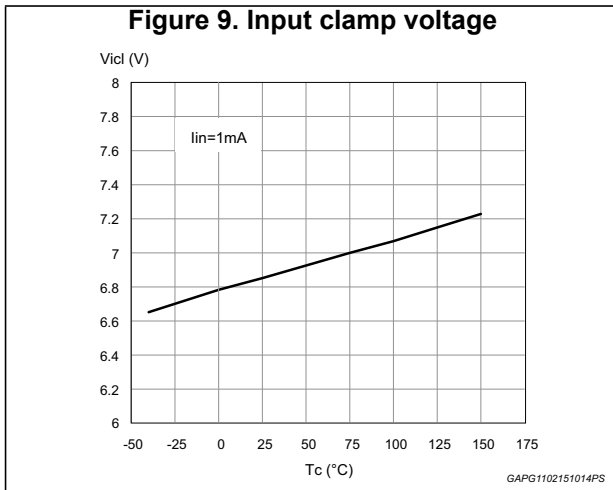
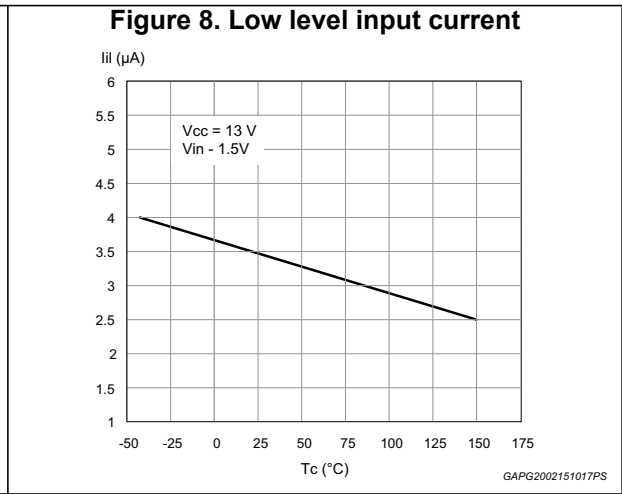
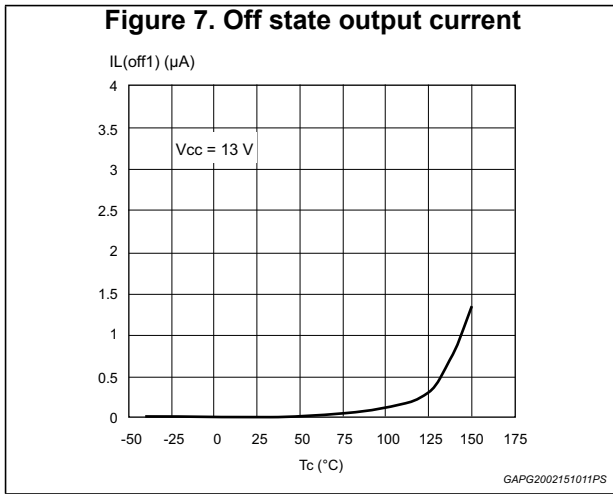

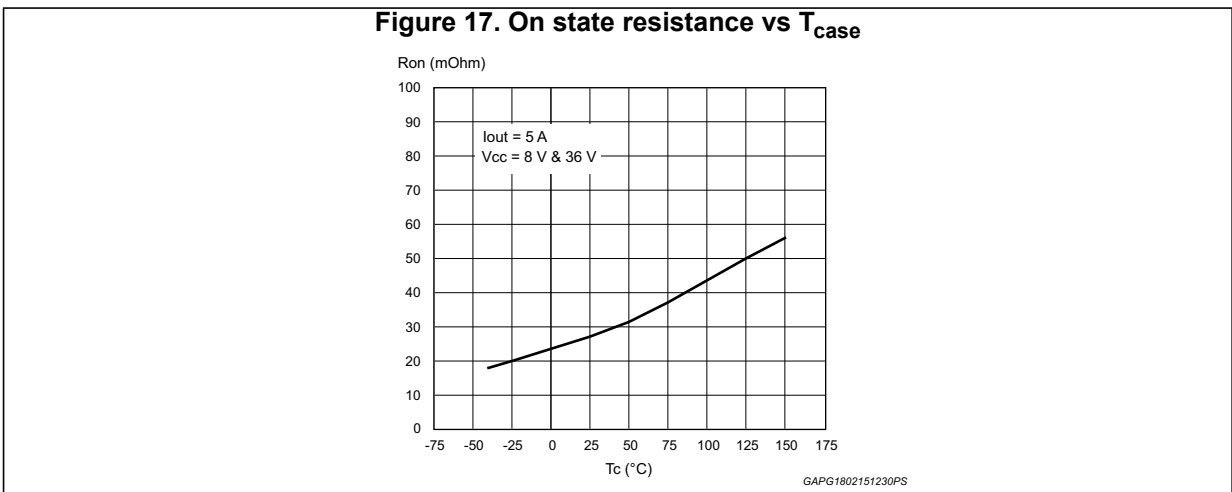
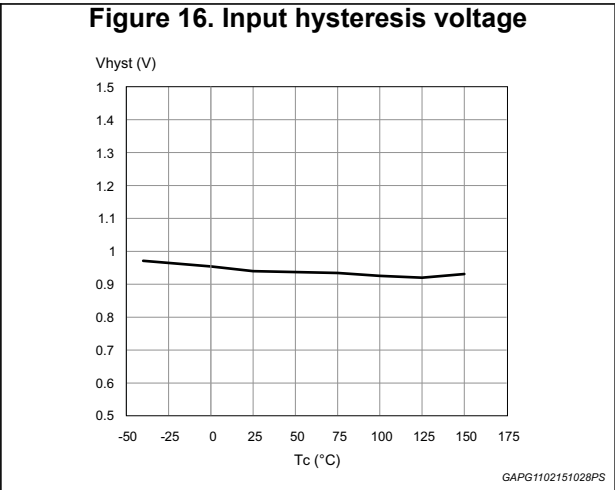
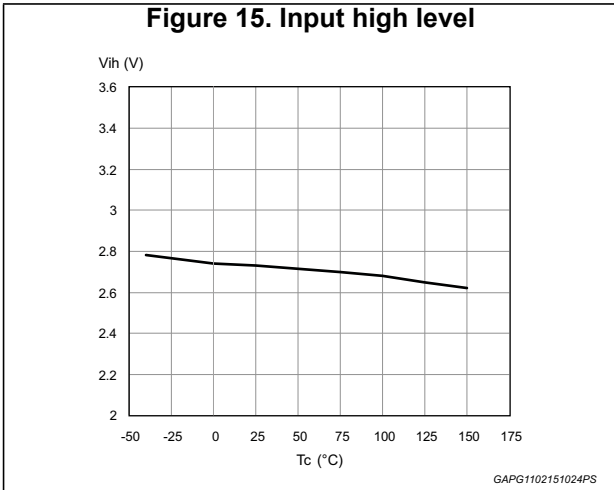
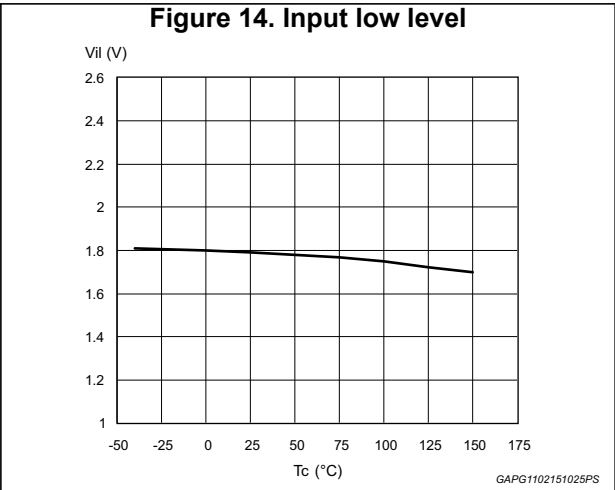
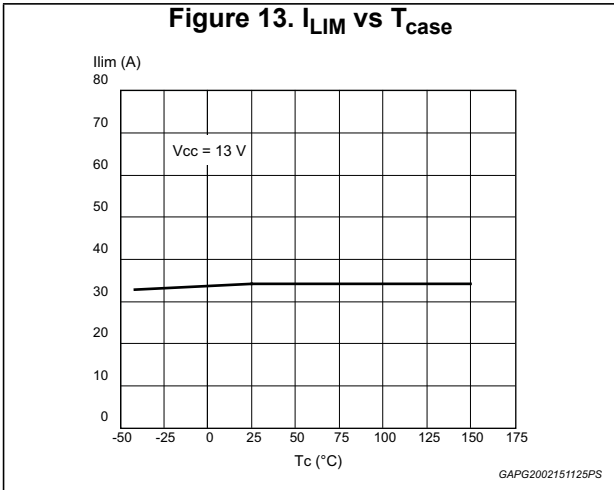



## 4 Application information

Figure 18. Application schematic

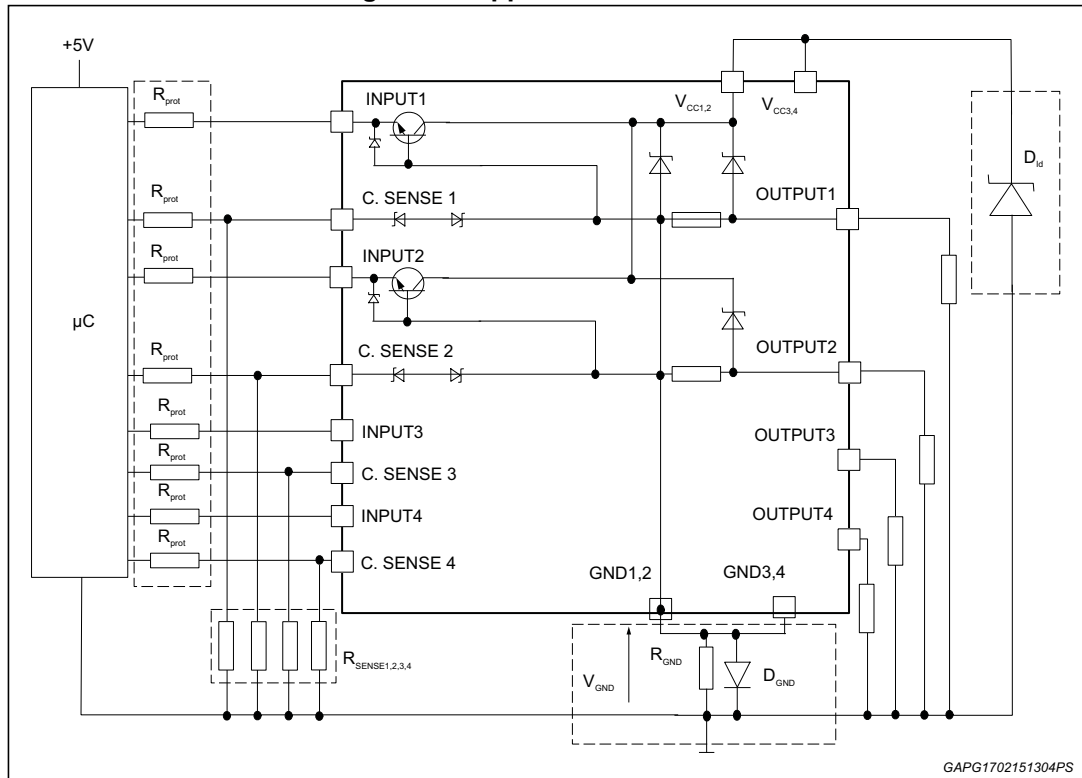

Note: Channels 3 & 4 have the same internal circuit as channel 1 & 2.

### 4.1 GND protection network against reverse battery

This section provides two solutions for implementing a ground protection network against reverse battery.

#### 4.1.1 Solution 1: a resistor in the ground line ( $R_{GND}$ only)

This can be used with any type of load.

The following show how to dimension the  $R_{GND}$  resistor:

1.  $R_{GND} \leq 600\text{mV} / 2(I_{S(on)max})$
2.  $R_{GND} \geq (-V_{CC}) / (-I_{GND})$

where  $-I_{GND}$  is the DC reverse ground pin current and can be found in the absolute maximum rating section of the device datasheet.

Power dissipation in  $R_{GND}$  (when  $V_{CC} < 0$  during reverse battery situations) is:

$$P_D = (-V_{CC})^2 / R_{GND}$$

This resistor can be shared amongst several different HSDs. Please note that the value of this resistor should be calculated with formula (1) where  $I_{S(on)max}$  becomes the sum of the maximum on-state currents of the different devices.

Please note that, if the microprocessor ground is not shared by the device ground, then the  $R_{GND}$  will produce a shift ( $I_{S(on)max} * R_{GND}$ ) in the input thresholds and the status output values. This shift will vary depending on how many devices are ON in the case of several high side drivers sharing the same  $R_{GND}$ .

If the calculated power dissipation requires the use of a large resistor, or several devices have to share the same resistor, then ST suggests using solution 2 below.

#### 4.1.2 Solution 2: a diode ( $D_{GND}$ ) in the ground line

A resistor ( $R_{GND}=1k\Omega$ ) should be inserted in parallel to  $D_{GND}$  if the device will be driving an inductive load. This small signal diode can be safely shared amongst several different HSD. Also in this case, the presence of the ground network will produce a shift ( $\pm 600mV$ ) in the input threshold and the status output values if the microprocessor ground is not common with the device ground. This shift will not vary if more than one HSD shares the same diode/resistor network. Series resistor in INPUT and STATUS lines are also required to prevent that, during battery voltage transient, the current exceeds the Absolute Maximum Rating. Safest configuration for unused INPUT and STATUS pin is to leave them unconnected.

## 4.2 Load dump protection

$D_{ld}$  is necessary (Voltage Transient Suppressor) if the load dump peak voltage exceeds the  $V_{CC}$  maximum DC rating. The same applies if the device is subject to transients on the  $V_{CC}$  line that are greater than those shown in the ISO T/R 7637/1 table.

## 4.3 MCU I/O protection

If a ground protection network is used and negative transients are present on the  $V_{CC}$  line, the control pins will be pulled negative. ST suggests to insert a resistor ( $R_{prot}$ ) in line to prevent the  $\mu C$  I/O pins from latching up.

The value of these resistors is a compromise between the leakage current of  $\mu C$  and the current required by the HSD I/Os (Input levels compatibility) with the latch-up limit of  $\mu C$  I/Os:

$$-V_{CCpeak}/I_{latchup} \leq R_{prot} \leq (V_{OH\mu C} - V_{IH} - V_{GND}) / I_{IHmax}$$

### Example

For the following conditions:

$$V_{CCpeak} = -100 V$$

$$I_{latchup} \geq 20 mA$$

$$V_{OH\mu C} \geq 4.5V$$

$$5 k\Omega \leq R_{prot} \leq 65 k\Omega.$$

Recommended values are:

$$R_{prot} = 10 k\Omega$$

### 4.4 Maximum demagnetization energy ( $V_{CC} = 13.5\text{ V}$ )

Figure 19. Maximum turn-off current versus load inductance

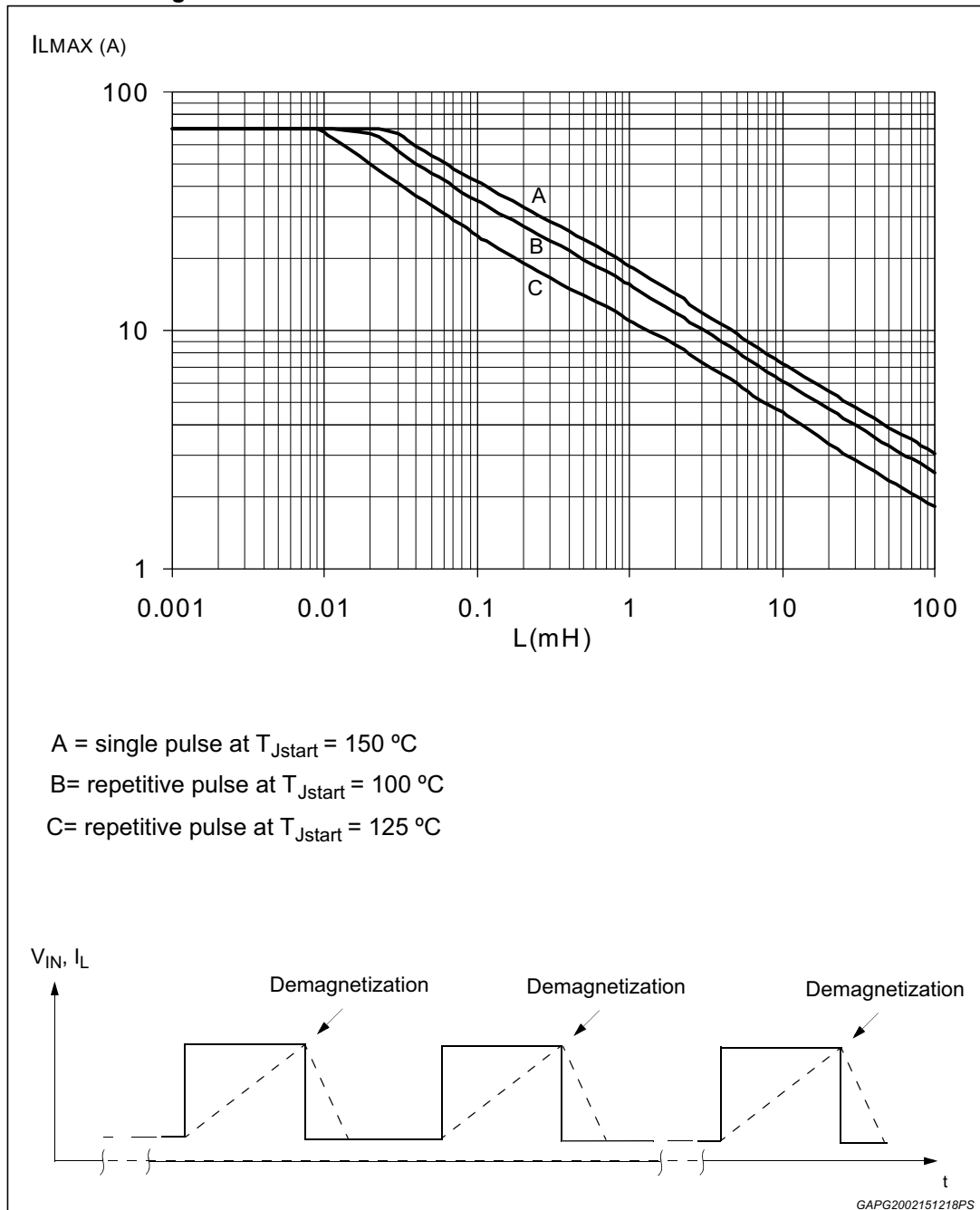

Note: Values are generated with  $R_L = 0\Omega$ .  
 In case of repetitive pulses,  $T_{Jstart}$  (at beginning of each demagnetization) of every pulse must not exceed the temperature specified above for curves B and C.

## 5 Package and PCB thermal data

### 5.1 SO-28 thermal data

Figure 20. SO-28 PC board

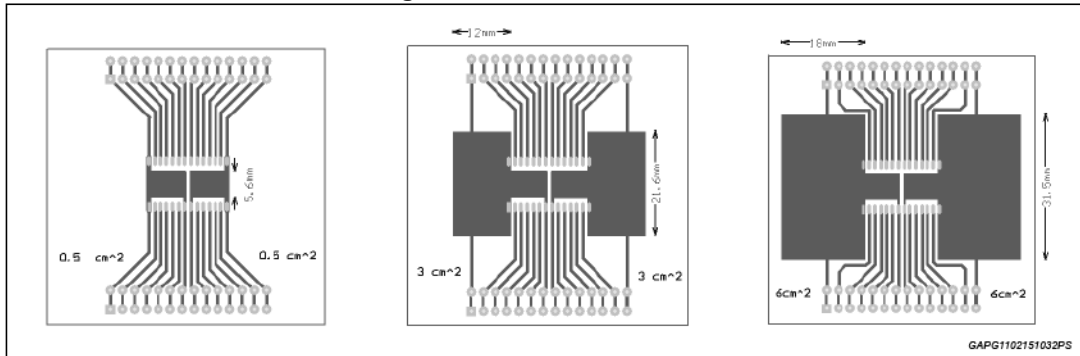

Note: Layout condition of  $R_{th}$  and  $Z_{th}$  measurements (PCB FR4 area= 58mm x 58mm, PCB thickness=2mm, Cu thickness=35 $\mu$ m, Copper areas: 0.5 cm<sup>2</sup>, 3 cm<sup>2</sup>, 6 cm<sup>2</sup>).

Table 15. Thermal calculation according to the PCB heatsink area

Chip 1	Chip 2	$T_{jchip1}$	$T_{jchip2}$	Note
ON	OFF	$R_{thA} \times P_{dchip1} + T_{amb}$	$R_{thC} \times P_{dchip1} + T_{amb}$	
OFF	ON	$R_{thC} \times P_{dchip2} + T_{amb}$	$R_{thA} \times P_{dchip2} + T_{amb}$	
ON	ON	$R_{thB} \times (P_{dchip1} + P_{dchip2}) + T_{amb}$	$R_{thB} \times (P_{dchip1} + P_{dchip2}) + T_{amb}$	$P_{dchip1} = P_{dchip2}$
ON	ON	$(R_{thA} \times P_{dchip1}) + R_{thC} \times P_{dchip2} + T_{amb}$	$(R_{thA} \times P_{dchip2}) + R_{thC} \times P_{dchip1} + T_{amb}$	$P_{dchip1} \neq P_{dchip2}$

$R_{thA}$  = Thermal resistance Junction to Ambient with one chip ON

$R_{thB}$  = Thermal resistance Junction to Ambient with both chips ON and  $P_{dchip1} = P_{dchip2}$

$R_{thC}$  = Mutual thermal resistance

Figure 21.  $R_{thj-amb}$  Vs PCB copper area in open box free air condition

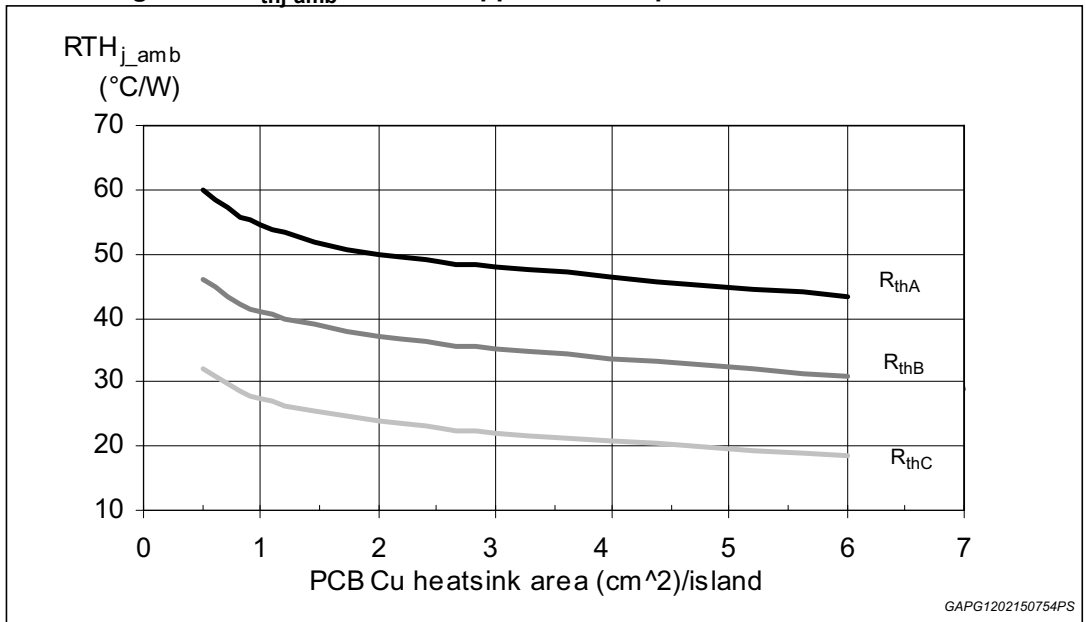
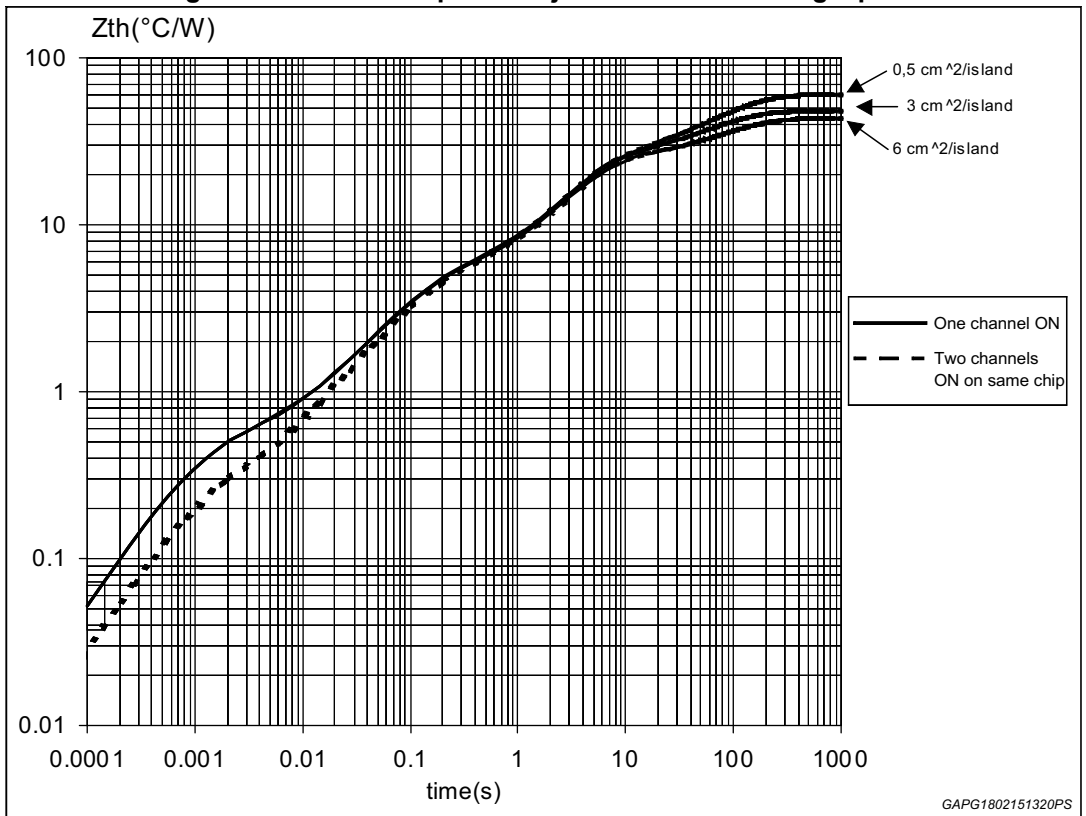

Figure 22. Thermal impedance junction ambient single pulse



**Equation 1:** pulse calculation formula

$$Z_{TH\delta} = R_{TH} \cdot \delta + Z_{THtp}(1 - \delta)$$

where  $\delta = t_p/T$

**Figure 23. Thermal fitting model of a quad channel HSD in SO-28**

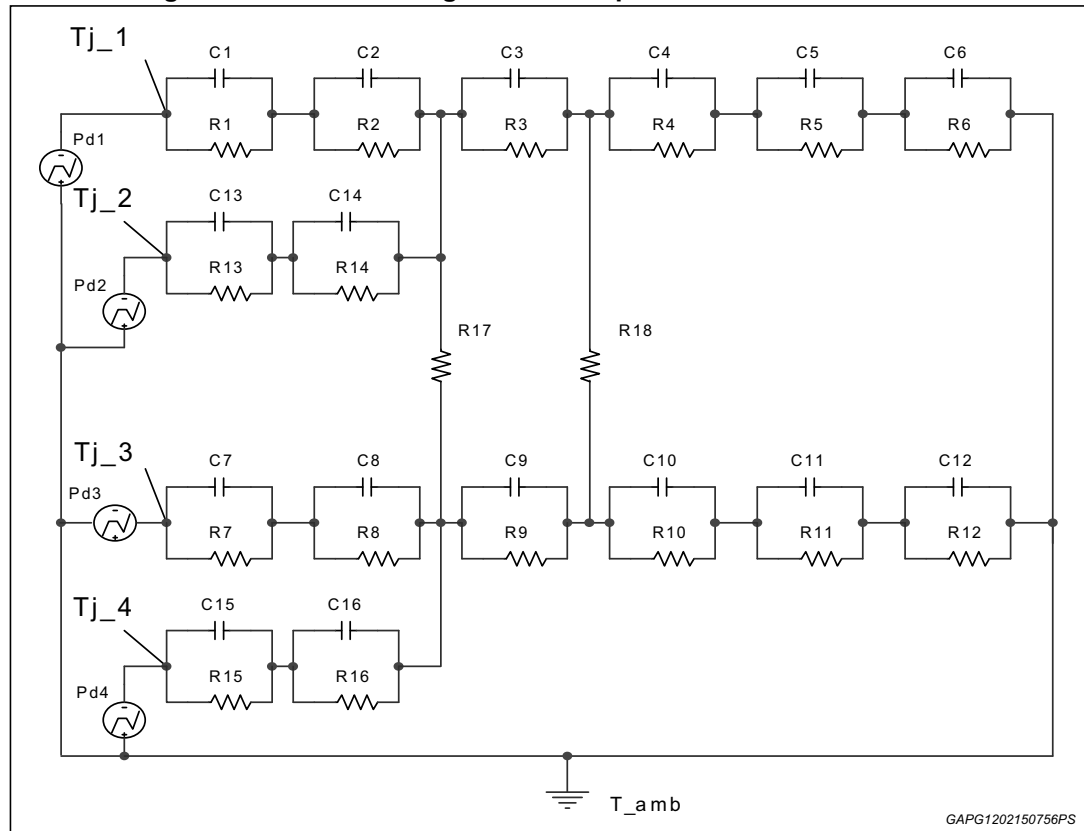

**Table 16. Thermal parameters**

Area/island (cm <sup>2</sup> )	0.5	6
R1=R7=R13=R15 (°C/W)	0.05	
R2=R8=R14=R16 (°C/W)	0.3	
R3=R9 (°C/W)	3.4	
R4=R10 (°C/W)	11	
R5=R11 (°C/W)	15	
R6=R12 (°C/W)	30	13
C1=C7=C13=C15 (W.s/°C)	0.001	
C2=C8=C14=C16 (W.s/°C)	5.00E-03	
C3=C9 (W.s/°C)	1.00E-02	
C4=C10 (W.s/°C)	0.2	
C5=C11 (W.s/°C)	1.5	
C6=C12 (W.s/°C)	5	8
R17=R18 (°C/W)	150	

## 6 Package information

In order to meet environmental requirements, ST offers these devices in different grades of ECOPACK<sup>®</sup> packages, depending on their level of environmental compliance. ECOPACK<sup>®</sup> specifications, grade definitions and product status are available at: [www.st.com](http://www.st.com). ECOPACK<sup>®</sup> is an ST trademark.

### 6.1 SO-28 package information

Figure 24. SO-28 package outline

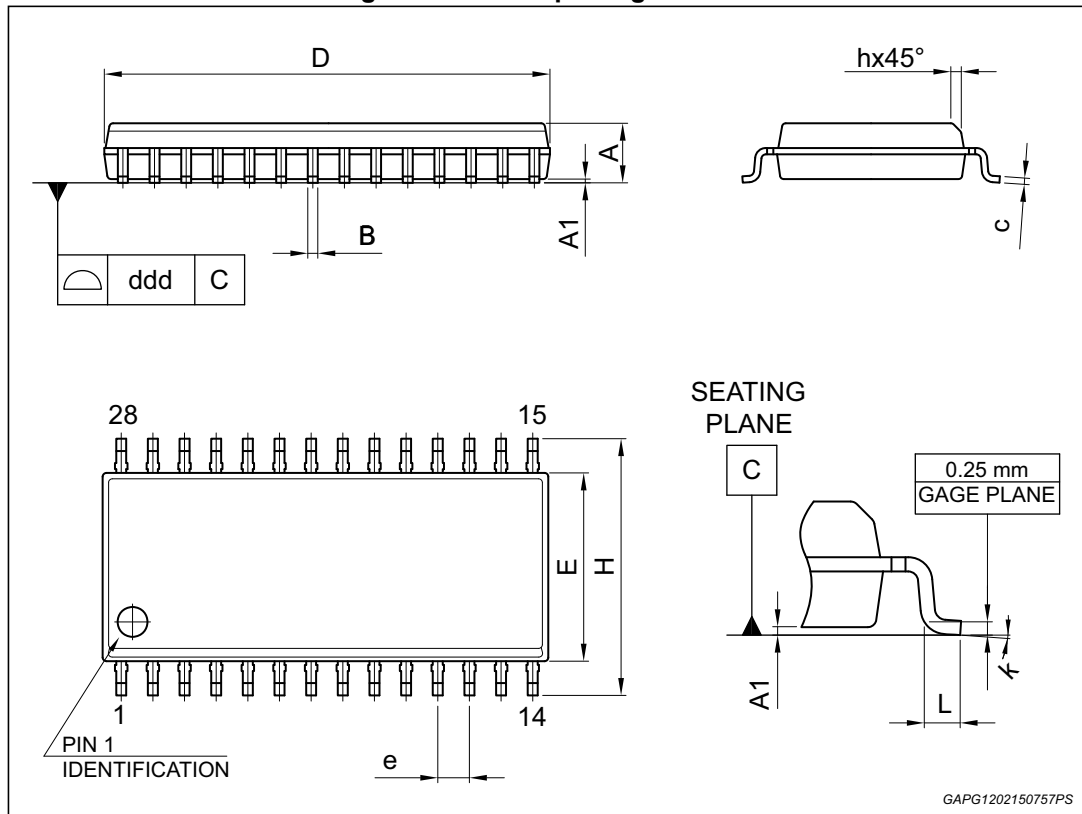

Table 17. SO-28 mechanical data

Ref.	Dimensions		
	Millimeters		
	Min.	Typ.	Max.
A	2.35		2.65
A1	0.10		0.30
B	0.33		0.51
C	0.23		0.32
D <sup>(1)</sup>	17.70		18.10

Table 17. SO-28 mechanical data

Ref.	Dimensions		
	Millimeters		
	Min.	Typ.	Max.
E	7.40		7.60
e		1.27	
H	10.0		10.65
h	0.25		0.75
L	0.40		1.27
k	0°		8°
ddd			0.10

1. Dimension "D" does not include mold flash, protrusions or gate burrs.  
Mold flash, protrusions or gate burrs shall not exceed 0.15mm per side.



## 6.2 SO-28 packing information

Figure 25. SO-28 tube shipment (no suffix)

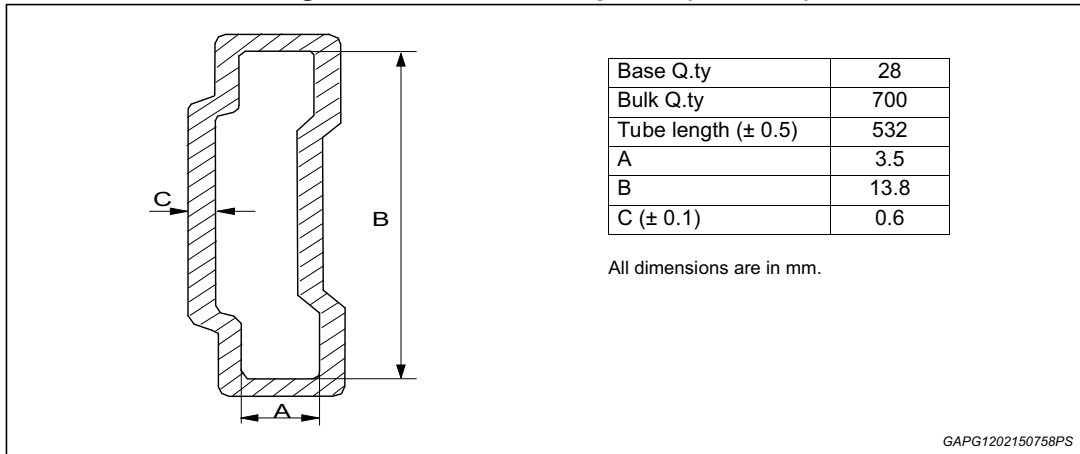
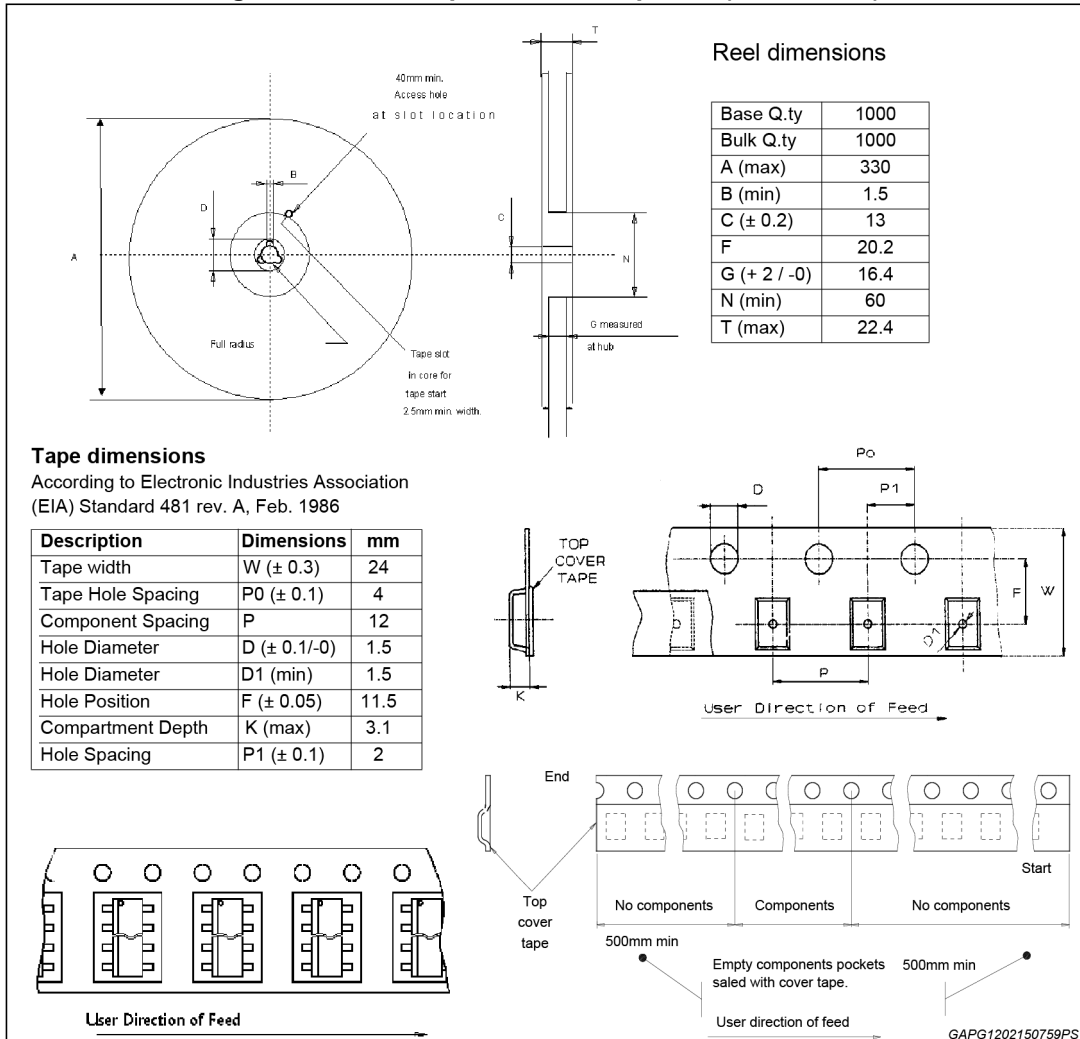

Figure 26. SO-28 tape and reel shipment (suffix “TR”)



## 7 Revision history

**Table 18. Document revision history**

Date	Revision	Changes
Oct-2004	1	Initial release.
02-Jul-2006	2	Added <i>Table 18: Document revision history</i> .
11-Nov-2008	3	Document converted to corporate template.
25-Sep-2013	4	Updated disclaimer.
20-Feb-2015	5	Updated: <ul style="list-style-type: none"><li>– <i>Section 6.1: SO-28 package information</i>;</li><li>– Tape dimensions in <i>Figure 26: SO-28 tape and reel shipment (suffix “TR”) on page 25</i>.</li></ul>

**IMPORTANT NOTICE – PLEASE READ CAREFULLY**

STMicroelectronics NV and its subsidiaries (“ST”) reserve the right to make changes, corrections, enhancements, modifications, and improvements to ST products and/or to this document at any time without notice. Purchasers should obtain the latest relevant information on ST products before placing orders. ST products are sold pursuant to ST’s terms and conditions of sale in place at the time of order acknowledgement.

Purchasers are solely responsible for the choice, selection, and use of ST products and ST assumes no liability for application assistance or the design of Purchasers’ products.

No license, express or implied, to any intellectual property right is granted by ST herein.

Resale of ST products with provisions different from the information set forth herein shall void any warranty granted by ST for such product.

ST and the ST logo are trademarks of ST. All other product or service names are the property of their respective owners.

Information in this document supersedes and replaces information previously supplied in any prior versions of this document.

© 2015 STMicroelectronics – All rights reserved