

PART NUMBER	REV	FIRST USED
565683-3	P	-

- 1 RECOMMENDED SPARE PARTS.
- 2 ITEMS NOT SHOWN.
- 3 USE P/N 684744-1, TOOL SPACER, BETWEEN RAM AND ALIGNMENT GAGE TO ALIGN APPLICATOR, FOR INITIAL SETUP ONLY.
- 4 CRIMP HEIGHT FOR INITIAL SET-UP ONLY.
- 5 GRIND TO LENGTH AT ASSEMBLY

TERMINAL NAME: 30° ROTATED PIGTAIL MINIATURE AMPLIVAR SPLICE	
200-2000	
.270 X .0126	
60656	
61166	
153212	
160631	
200-1700	
.016	
62044	
200 X 1700	
.200 X .014	
62341	
TERM APPL SPEC 114-2016	

CRIMPING DATA			
CRIMP	SIZE	TYPE	RANGE
WIRE	.070	F	200-2000 CMA
INSUL	-	-	-
FEED	.330	APPL INST	SET UP GAGE LAYOUT
			680229 3
WIRE STRIP LENGTH		.205-.235	

QTY	REV	PART NO	DESCRIPTION	ITEM NO
-	-	-	-	73
1	-	A 464249-1	PLATE, IDENTIFICATION	72
2	-	A 21017-2	SCR, DRIVE #2 X .19	71
-	-	-	-	70
1	-	A 460590-1	SPACER, AIR FEED	69
2	-	A 21001-8	SCR, SHC 1/4-20 X 1.00	68
1	-	C 465184-2	LUBRICATOR ASSY	67
1	-	D 690021-1	1" AIR FEED ASSY	66
1	-	A 374999	PLATE, TENSION, ADJ	65
-	-	-	-	64
-	-	-	-	63
-	-	-	-	62
-	-	-	-	61
-	-	-	-	60
-	-	-	-	59
1	-	A 551403-1	WASHER	58
2	-	A 371178	WASHER	57
-	-	-	-	56
1	-	A 452123-1	PLATE, SHEAR MT.	55
1	-	A 452122-1	SPACER, STRIP GUIDE	54
1	-	A 452120-1	COVER, GUIDE RAIL	53
3	-	A 1-22278-2	SPRING, COMP.	52
1	-	A 452119-1	RAIL, GUIDE	51
1	-	A 452118-1	PLATE, GUIDE RAIL	50
-	-	-	-	49
-	-	-	-	48
-	-	-	-	47
1	-	A 463215-2	PLATE, RETAINING	46
1	-	A 24017-3	SPRING, COMP.	45
1	-	A 452112-1	SLIDE, SHEAR	44
-	-	-	-	43
1	-	B 452117-2	PLATE, FEED	42
-	-	-	-	41
1	-	D 460374-2	GUARD	40
1	-	C 565147-2	BASE CASTING	39
-	-	-	-	38
1	-	B 551392-1	TIP, FINGER, FEED	37
1	-	B 473739-1	FINGER, FEED	36
1	-	B 386942	HOLDER, FINGER, FEED	35
-	-	-	-	34
1	-	A 373469	SPRING, DRAG, STOCK	33
-	-	-	-	32
-	-	-	-	31
1	-	B 387650	DRAG, STOCK	30
-	-	-	-	29
-	-	-	-	28
-	-	-	-	27
-	-	-	-	26
1	-	A 689137-3	STRIPPER	25
-	-	-	-	24
-	-	-	-	23
-	-	-	-	22
1	-	B 452111-1	BLOCK, BASE	21
1	-	B 452110-1	PLATE, BASE	20
-	-	-	-	19
-	-	-	-	18
-	-	-	-	17
-	-	-	-	16
-	-	-	-	15
1	-	B 452121-1	GUIDE, STRIP, REAR	14
-	-	-	-	13
-	-	-	-	12
-	-	-	-	11
-	-	-	-	10
-	-	-	-	9
-	-	-	-	8
-	-	-	-	7
1	-	A 452129-1	PLATE, SHEAR, REAR	6
1	-	B 460663-3	BLADE, SHEAR	5
-	-	-	-	4
1	-	C 551379-4	ANVIL	3
-	-	-	-	2
1	-	C 452127-1	CRIMPER, WIRE	1

-	-	-	-	130	
-	-	-	-	129	
-	-	-	-	128	
-	-	-	-	127	
-	-	-	-	126	
-	-	-	-	125	
-	-	-	-	124	
-	-	-	-	123	
-	-	-	-	122	
-	-	-	-	121	
-	-	-	-	120	
-	-	-	-	119	
-	-	-	-	118	
-	-	-	-	117	
-	-	-	-	116	
-	-	-	-	115	
-	-	-	-	114	
-	-	-	-	113	
-	-	-	-	112	
-	-	-	-	111	
-	-	-	-	110	
-	-	-	-	109	
-	-	-	-	108	
-	-	-	-	107	
-	-	-	-	106	
-	-	-	-	105	
-	-	-	-	104	
-	-	-	-	103	
-	-	-	-	102	
-	-	-	-	101	
-	-	-	-	100	
-	-	-	-	99	
-	-	-	-	98	
-	-	-	-	97	
-	-	-	-	96	
-	-	-	-	95	
-	-	-	-	94	
3	-	A 21001-2	SCR, SHC 1/4-20 X .50	93	
1	-	A 2-21000-5	SCR, SHC 8-32 X .25	92	
2	-	A 21028-2	PIN, ROLL Ø.062 X .25	91	
1	-	A 21055-7	WASHER, FLAT #10	90	
1	-	A 21055-6	WASHER, FLAT #8	89	
1	-	A 21126-3	NUT, SELF LOCKING, 10-32	88	
3	-	A 3-21015-1	SCR, HEX HD 3/8-16X1.00	87	
1	-	A 8-21006-7	SCR, SOC SET 5-40 X .125	86	
1	-	A 2-21001-1	SCR, SHC 5/16-18 X 1.25	85	
2	-	A 21001-4	SCR, SHC 1/4-20 X .62	84	
3	-	A 21001-2	SCR, SHC 1/4-20 X .50	83	
2	-	A 4-21000-3	SCR, SHC 10-32 X 2.00	82	
3	-	A 3-21000-5	SCR, SHC 10-32 X .50	81	
4	-	A 3-21000-4	SCR, SHC 10-32 X .38	80	
1	-	A 2-21000-5	SCR, SHC 8-32 X .25	79	
4	-	A 2-21000-8	SCR, SHC 8-32 X .62	78	
2	-	A 2-21000-6	SCR, SHC 8-32 X .38	77	
4	-	A 1-21000-9	SCR, SHC 6-32 X .38	76	
6	-	A 1-21000-3	SCR, SHC 4-40 X .25	75	
-	-	-	-	74	
-7	U/M	DWG SIZE	PART NO	DESCRIPTION	ITEM NO
				REVISION OF EACH ASSY NO (WHEN BLANK, USE DWG REVISION)	

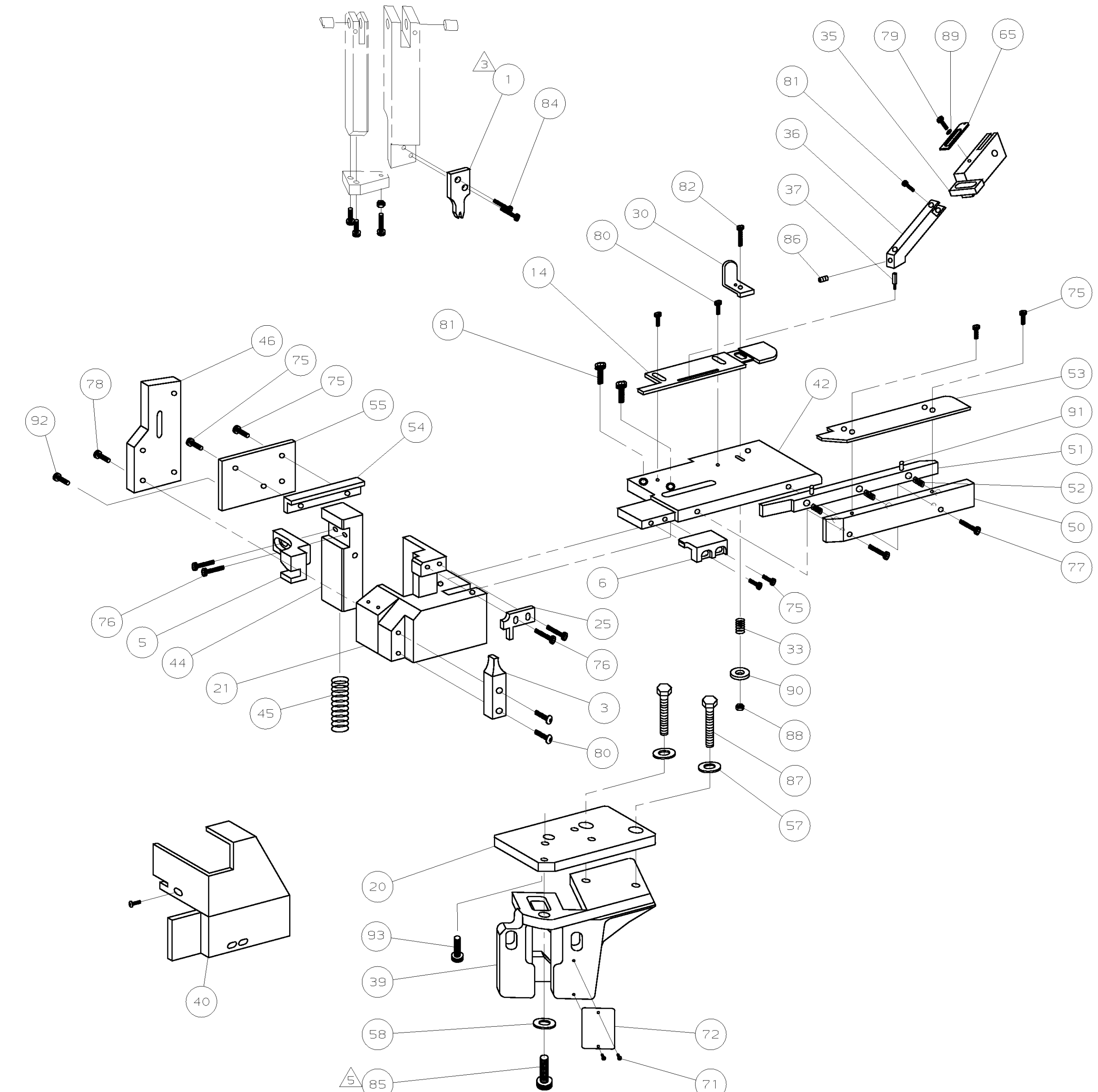

THIS DRAWING IS A CONTROLLED DOCUMENT.

RELEASED FOR PUBLICATION APR 30, 1999  
 BY AMP INCORPORATED. ALL RIGHTS RESERVED.  
 THIS DRAWING IS UNCLASSIFIED  
 COPYRIGHT 1999

LOC A  
 DIST 4

QTY REQD PER ASSY		PARTS LIST	
DIMENSIONS IN INCHES. DO NOT SCALE PRINT. TOLERANCES UNLESS OTHERWISE SPECIFIED:		MATL	HT TR
2 PLC DEC ±			FIN
3 PLC DEC ±		DR 5/17/93 APP 12-22-93 R. LEHR/UTA B A WOLFE CHK 12-22-93 REL 1/31/94 C ERISMAN B. MORGAN	
4 PLC DEC ±		<b>AMP</b> AMP Incorporated Harrisburg, PA 17105-3608	
ANGLES ± -		NAME	
SURF TEXTURE, AUTCP		STD APPL (30 DEG ROTATED SPLICE)	
REMOVE BURRS, BREAK SHARP EDGES R.015 MAX		MACHINE REF	
SCALE 1:4		STD APPL	
DWG NO 565683-3		SHEET 1 OF 1	
CASE CODE 00779		REV P	