

JWS 240P·480P Series

Instruction Manual

BEFORE USING THE POWER SUPPLY UNIT

Pay attention to all warnings and cautions before using the unit. Incorrect usage could lead to an electrical shock, damage to the unit or a fire hazard.

WARNING and CAUTION

- Do not modify nor remove cover.
- Do not touch the internal components, they may have high voltage or high temperature. You may get electrical shock or burned.
- When the unit is operating, keep your hands and face away from it; you may get injured by an accident.
- This power supply is primarily designed and manufactured to be used and enclosed in other equipment. Stick the WARNING label for users on the system equipment and describe the notice in the instruction manual.
- Never operate the unit under over current or shorted conditions for long time which could result in damage or insulation failure. There is no possibility for fire or burning.
- Confirm connections to input/output terminals are correct as indicated in the instruction manual.
- This power supply has a possibility that hazardous voltage may occur in output terminal depending on failure mode.
The outputs of these products must be earthed in the end use equipment to maintain SELV.
If the outputs are not earthed, they must be considered hazardous and must not be made user accessible.

Note: CE MARKING

CE Marking, when applied to a product covered by this handbook indicates compliance with the low voltage directive (73/23/EEC) as modified by the CE Marking Directive (93/68/EEC) in that it complies with EN60950.

DWG NO. : A182-04-01B		
APPD	CHK	DWG
M. TANE MURA	<i>Handwritten signature</i>	A. Haga
16 Jun.'05	16 Jun.'05	16 Jun.'05

1. Front Panel Explanation

JWS240P Panel

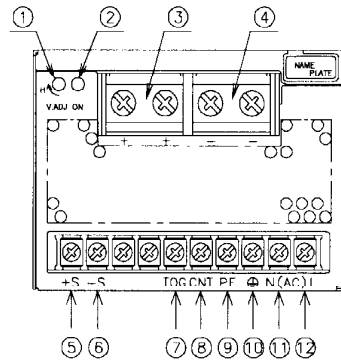

- (1) V.ADJ : Output voltage adjust trimmer
(The output voltage rises when a trimmer is turned clockwise.)
- (2) ON : Output (Power On) indication LED
(The indicator turns on when the power supply output is in normal operating condition.)
- (3) + : + Output terminal (M5 screw x 2)
- (4) - : - Output terminal (M5 screw x 2)
- (5) +S : Remote sensing terminal for + output
(for remote sensing function, this compensates for line drop between power supply terminals and load terminals.)
- (6) -S : Remote sensing terminal for - output
(for remote sensing function which compensates for line drop between power supply terminals and load terminals.)

JWS480P Panel

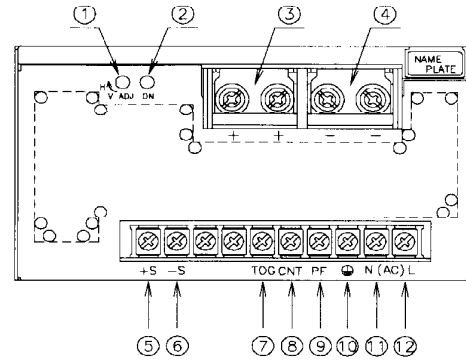

- (7) TOG : Ground for CNT and PF signal
- (8) CNT : ON/OFF control terminal
(for power supply output on and off control with an external signal.)
- (9) PF : Power fail signal output terminal
(As the output voltage drops, "Power Fail" terminal will output "High".)
- (10) \oplus : Safety Earth (Frame ground)
- (11) AC input terminal N : Neutral line
- (12) AC input terminal L : Live Line (Fuse in line)

2. Terminal Connection Method

- Input must be off when making connection.
- Connect \ominus terminal to ground terminal of the equipment.
- The output load line and input line shall be separated and twisted to improve noise sensitivity.
- Remote sensing lines shall be twisted or use shielded wire.
- Remote ON/OFF control lines shall be twisted or use shielded wire.

JWS240P Panel Side (Common JWS480P)

■ Basic connection (Local sensing)

Connect “+S” terminal to “+” terminal and “-S” terminal to “-” terminal with sensing wires. Connect “CNT” terminal to “TOG” terminal with the short piece.

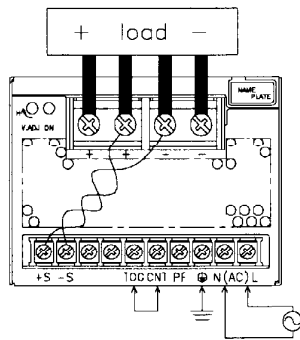

■ ON/OFF control required

Remove the short piece on “CNT” and “TOG” terminals. “TOG” terminal is ground for “CNT” terminal.

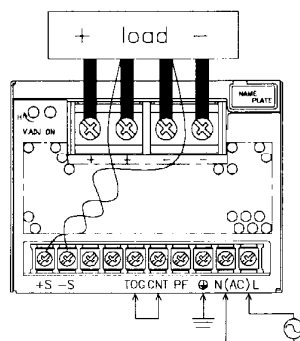

■ Remote sensing required

Connect “+S” terminal to “+” terminal of load and “-S” terminal to “-” output terminal of load with wires. When remote sensing terminals are opened, output is shut down.

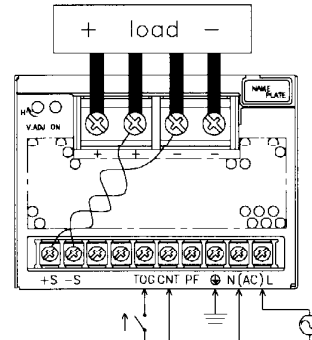

■ PF signal output required

Open collector method shown below shall be used. “TOG” terminal is ground for “PF” terminal.

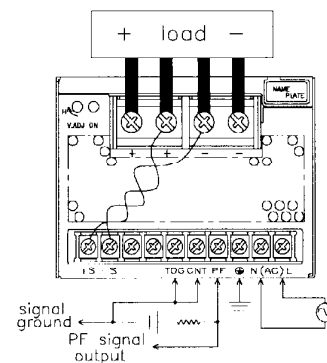

3. Functions and Precautions

3-1. Input Voltage Range

Input voltage range is single phase 85 ~ 265 VAC (47 ~ 63Hz). Input voltage which is out of specification may cause unit damage.

3-2. Output Voltage Range

V.ADJ trimmer on the front panel side can adjust the output voltage within the range. Output voltage range is within +20% ~ -10% of nominal output voltage (48V Output Model : ±10%). To turn the trimmer clockwise, the output voltage will be increased. Note over voltage protection (OVP) function may trigger if the output voltage is increased excessively.

3-3. Over Voltage Protection (OVP)

The OVP function (Inverter shut down method, manual reset type) is provided. When OVP triggers, the output will be shut down. The input shall be removed for a few minutes, and then re-input for recovery of the output. OVP setting shall be fixed and not to be adjusted externally.

3-4. Over Current Protection (OCP)

Constant current limiting, automatic recovery. OCP function operates when the output current exceeds 204% of average output current on specification. The output will be automatically recovered when the overload condition is canceled. When the unit operate under over peak current for more than 10 seconds, the output voltage will shut down. Remove the input for a few minutes, and then re-input for recovery of the output.

3-5. Over Temperature Protection (OTP)

Over temperature protection function is provided. When ambient or internal temperature rises abnormally, OTP will shut down the output. After shut down, first remove the input and cool it down before re-input.

3-6. Low Output Detection Circuit

Low output detection circuit is provided. PF signal will turn "High" level to indicate the abnormal status when the output voltage becomes within 65 ~ 80% of rated value caused by either the drop or brown out of the input voltage or OCP, OVP and OTP function operation. The PF signal is insulated by a photo coupler. It uses the open collector method shown in below.

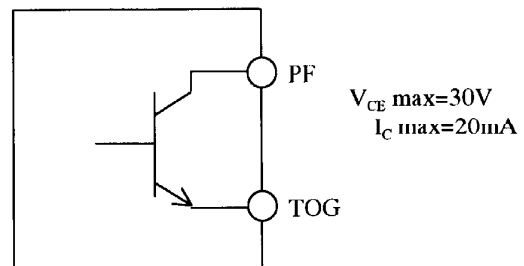

3-7. Remote Sensing (+S, -S terminal)

This function compensates voltage drop of wiring from output terminals to load terminals. Connect "+S" terminal to "+" terminal of load and "-S" terminal to "-" terminal of load with sensing wires. The total line voltage drop (+ side line and - side line) shall be less than 0.3V. In case that sensing line is too long, it is necessary to put an electrolytic capacitor in following 3 placed;

- 1) Across the load terminal,
- 2) Between "+S" terminal and "+" terminal,
- 3) Between "-S" terminal and "-" terminal.

If remote sensing terminals are opened, the output will rise and OVP may be triggered.

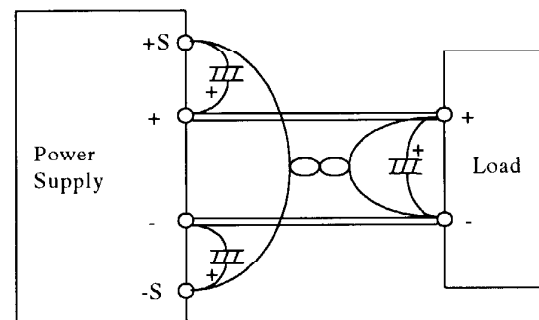

3-8. Remote ON/OFF Control

Remote ON/OFF control is provided. Using this function, output on/off is allowed to control without input voltage on/off. The output is turned to ON when TOG and CNT terminals are shorted: the output is turned to OFF when these terminals are opened. When the function is not used, connect TOG and CNT terminals with short piece. The standards for this function are as follows.

- (1) TTL compatible. The maximum input voltage to CNT terminal is 12V, and the maximum allowable reverse voltage is -1V. The sink current of CNT terminal is 3.5mA.
- (2) A switch and relay or a transistor can be used as an ON/OFF switch.
- (3) This circuit is isolated from the input and output by a photocoupler. Connect TOG terminal to ground of control signal.

Control mode is shown below.

CNT Level for TOG Terminal	Output Condition
short or L (0V ~ 0.8V)	ON
Open or H (2.4V ~ 12V)	OFF

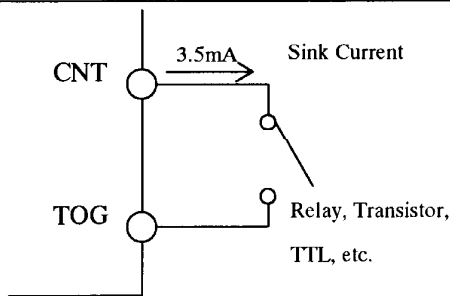

3-9. Output Ripple & Noise

The standard specification for maximum ripple value is measured according to measurement circuit specified by EIAJ-RC9131. When load lines are longer, ripple becomes larger. In this case, electrolytic capacitor, film capacitor, etc. might be necessary to use across the load terminal.

The output ripple cannot be measured accurately if the probe ground lead of oscilloscope is too long.

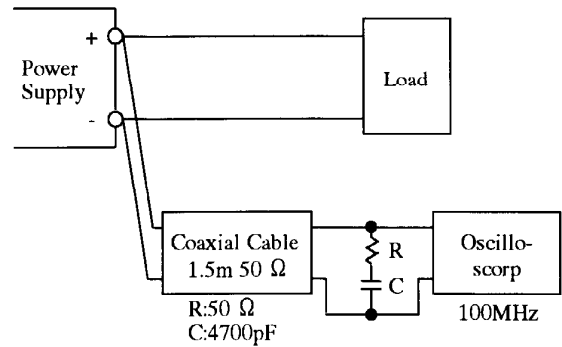

3-10. Series Operation

For series operation, either method (A) or (B) is possible.

Method (A)

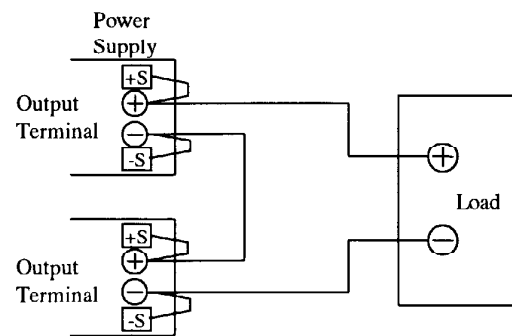

Method (B)

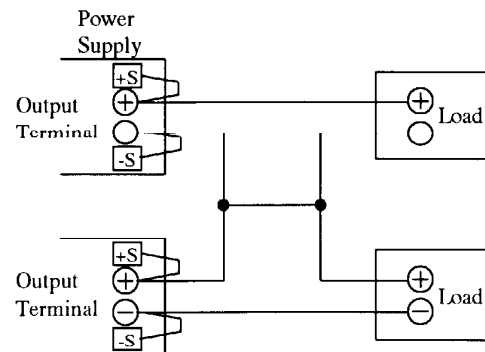

3-11. Remote Programming

Connecting a remote programming resistor such as a potentiometer between “+S” and “+” terminal, remote programming becomes possible to use. The rate of the change due to the remote programming resistor is 1V/kΩ. The output voltage range is +20% ~ -10% of the nominal output voltage (48V Output Model : ±10%).

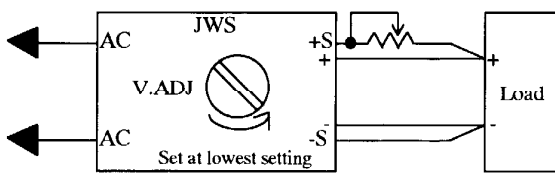

4-2. Withstand Voltage

This series is designed to withstand 3.0kVAC between input and output, 2.0kVAC between input and FG (chassis), 500VAC between output and FG (chassis), and 100VAC between output and control terminal each for 1 minute. When testing withstand voltage, set current limits of withstand voltage test equipment at 20mA (Output-FG (chassis) and Output-Control: 100mA). The applied voltage must be gradually increased from zero to testing value and then gradually decreased for shut down. When timer is used, the power supply may be damaged by high impulse voltage at timer switch on and off. Connect input and output as follows.

4. Isolation/Withstand Voltage

4-1. Isolation Test

Isolation resistance between output and FG (chassis) shall be more than 100MΩ at 500VDC and between output and control shall be more than 10MΩ at 100VDC. For safety operation, voltage setting of DC isolation tester must be done before the test. Ensure that it is fully discharged after the test.

Input ~ FG (chassis) (solid line)

2.0kVAC 1min. (20mA)

Input ~ Output (dotted line)

3.0kVAC 1min. (20mA)

Output ~ FG (chassis)

500VDC 100MΩ or more

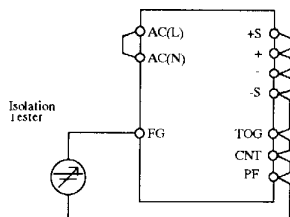

Output ~ Control

100VDC 10MΩ or more

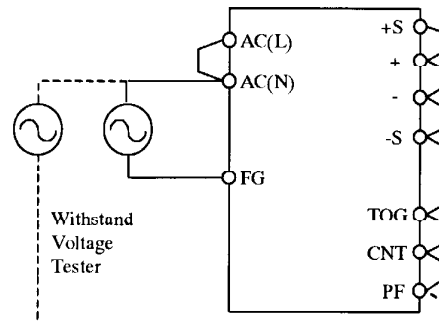
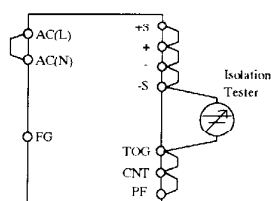

Output ~ FG (chassis)

500VAC 1min. (100mA)

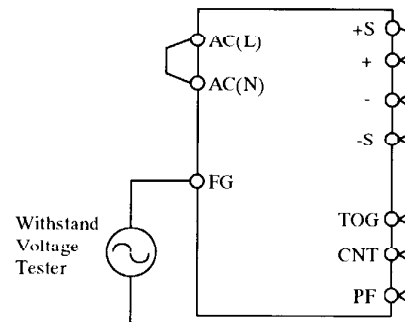

Output ~ Control
100VAC 1min. (100mA)

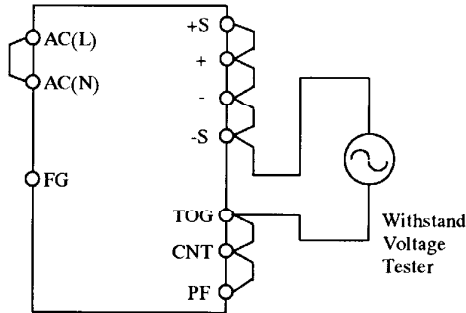

5. Peak Output Current

For JWS-P series, relation between average output current and peak output current must satisfy formulas below. Also operating time at peak output current should be less than 10sec. (Duty ≤ 0.5)

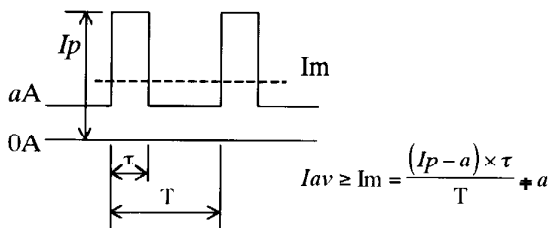
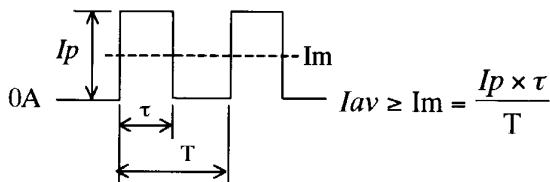

- I_p : Peak output current (A)
- I_{av} : Average output current of Specification (A)
- I_m : Average output current (A)
- τ : Pulse width of peak output current (sec)
- (Operating time at peak output)
- T : Period (sec)

6. Mounting Directions

6-1. Output Derating according to the Mounting Directions

Recommended standard mounting method is (A). Method (B), (C) and (D) are also possible. Refer to the derating below. In the following derating curve, the average output current is considered to be 100%.

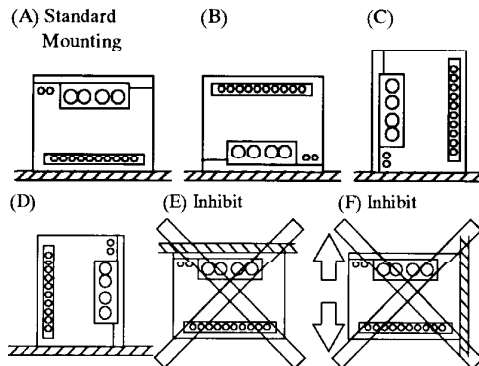

JWS240P Output Derating

Ta(°C)	AVERAGE LOAD(%)			
	A	B	C	D
-10 ~ +35	100	100	100	100
45	100	100	100	70
50	100	100	100	55
60	70	70	70	-
65	55	55	55	-

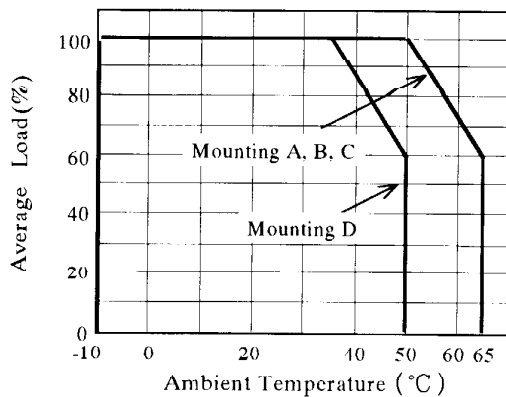

JWS240P Derating curve

JWS480P Output Derating

Ta(°C)	AVERAGE LOAD(%)			
	A	B	C	D
-10 ~ +35	100	100	100	100
45	100	100	70	100
50	100	100	55	100
60	70	70	-	70
65	55	55	-	55

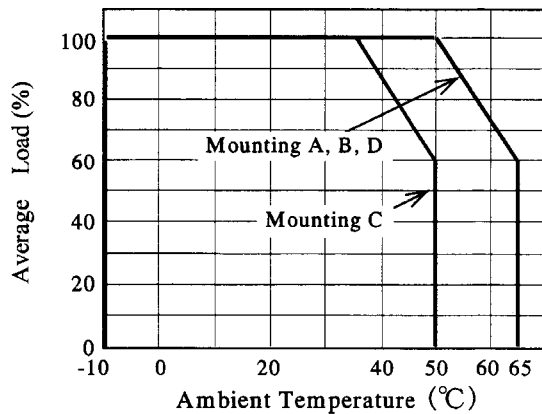

JWS480P Derating curve

6-2. Mounting Method

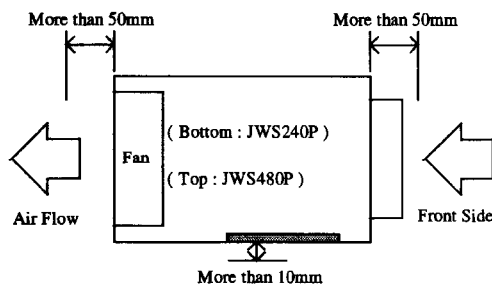

- (1) Forced air cooling type power supply. This power supply has ventilating holes on the front, back, and side panels. Keep these three areas freely as much as possible.
- (2) The maximum allowable penetration of mounting screws is 6mm.
- (3) Recommended torque for mounting screw :
JWS240P·480P (M4 screw) : 1.27 N·m
(13.0 kgf·cm)

7. Wiring Method

- The output load line and input line shall be separated and twisted to improve noise sensitivity.
- The sensing lines shall be twisted and separated from the output lines.
- Use all lines as thick and short as possible to make lower impedance.
- Noise can be eliminated by attaching a capacitor to the load terminals.
- For safety and EMI considerations, connect \oplus terminal to the mounting set ground terminal.
- Recommended torque for the terminal piece:
Output terminal (M5 screw) : 2.50 N·m
(25.5 kgf·cm)
Input and signal terminal (M4 screw) :
1.27 N·m(13.0 kgf·cm)
- Recommended wire type
(JWS240P/508, JWS480P/508) :
Output terminal : AWG10-18(5.5-0.83mm²)
Input and signal terminal : AWG12-22
(3.5-0.3mm²)

8. External Fuse Rating

Refer to the following fuse rating when selecting the external fuses that are to be used on input line. Surge current flows when line turns on. Use slow-blow fuse or time-lag type fuse. Do not use fast-blow fuse. Fuse rating is specified by in-rush current value at line turn-on. Do not select the fuse according to input current (rms.) values under the actual load condition.

JWS240P: 10A
JWS480P: 20A

9. Fan life expectancy

The fan-life has limitation. Therefore, periodic maintenance by exchanging the life-expired fan is required. The following figure shows the life of the fan.

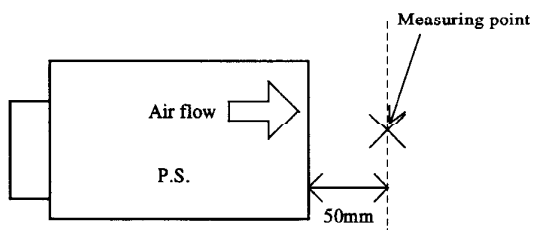
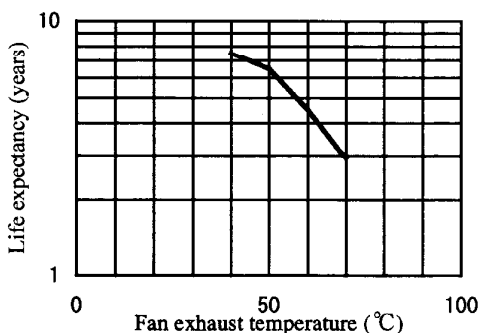

Measuring point of fan exhaust temperature.

10. Before concluding that the unit is at fault...

Before concluding that the unit is at fault, make the following checks.

- Check if the rated input voltage is connected.
- Check if the wiring of input and output is correct.
- Check if the wire material is not too thin.
- Check if the output voltage control (V.ADJ) is properly adjusted.
- If use function of the Remote ON/OFF control, Check if the Remote ON/OFF control connector is not opened.

- Check if the output current and output wattage dose not over specification.
- Audible noise can be heard during Dynamic-Load operation.
- Audible noise can be heard when input voltage waveform is not sinusoidal wave.

11. Notes

1. Overvoltage Category II
2. Radio Interference Suppression Test is not performed.

12. JWS240P/508, JWS480P/508

UL508 Listed Condition

1. Surrounding Air Temperature : 40°C
2. Wire Requirement
 - Use min. 60°C or 60/75°C wire.
 - Use copper conductor only.
3. For use in a Pollution degree 2 environment only.
4. Indoor use only.