

- NOTE 1 . ALL LEAD CO-PLANARITY SHALL BE 0.08mm MAX.
- 2 CONTACT PLATING SPECIFICATIONS
CONTACT AREA : GOLD 0.05 μm MIN
SMT LEAD : GOLD 0.05 μm MIN
UNDER PLATING : NICKEL 1 μm MIN
(SURFACE : SEALING)
 - 3 A PART OF THE WALL COULD BE NOTCHED.
 - 4 HRS MARK AND CAV No. ARE INDICATED IN APPROX. POSITION SHOWN.

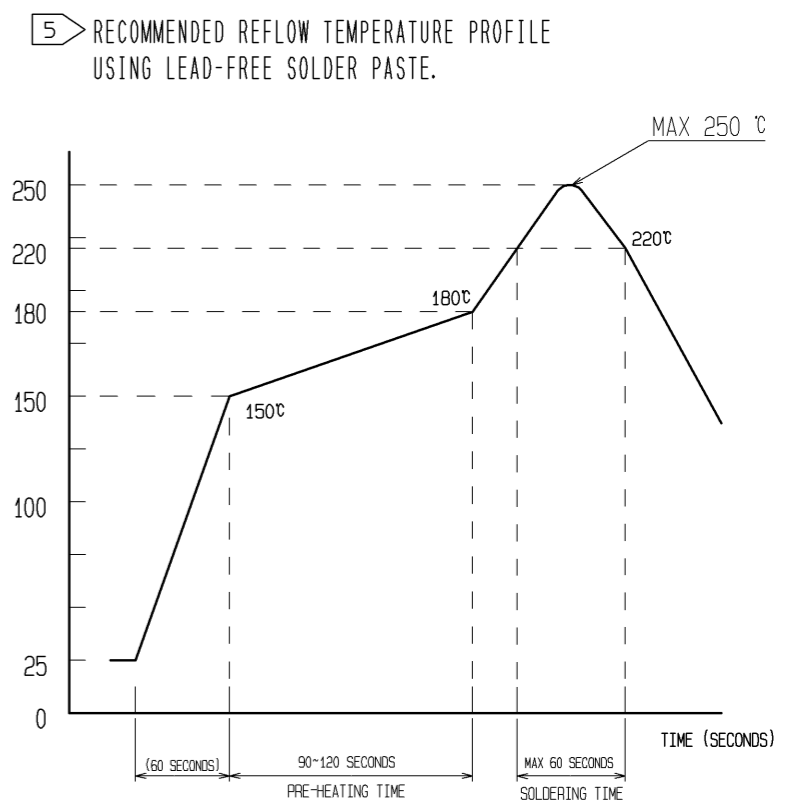

REFLOW METHOD: IR REFLOW
NUMBER OF REFLOW CYCLES: 2 CYCLES MAX.

1) REFLOW TIME
DURATION ABOVE 220°C, 60 SEC MAX.
(PEAK TEMPERATURE: 250°C MAX)

2) PRE-HEAT TIME
PRE-HEAT TEMPERATURE(MIN): 150°C
PRE-HEAT TEMPERATURE(MAX): 180°C
PRE-HEAT TIME: 90-120 SEC.

5 THIS TEMPERATURE PROFILE IS PER THE CONDITIONS SHOWN ABOVE. ADDITIONAL FACTORS, SUCH AS SOLDER PASTE TYPE, PCB SIZE AND OTHER MOUNTED COMPONENTS COULD AFFECT THE PROFILE. THEREFORE, A THOROUGH EVALUATION OF MOUNTING COONDITION IS REQUIRED PRIOR TO PRODUCTION. TEMPERATURE IS MEASURED AT CONTACT LEAD.

6. PLEASE CONTACT US IN CASE YOU WILL MAKE DIFFERENT SETTINGS FROM OUR RECOMMENDATION.

◆ RECOMMENDED PCB LAYOUT

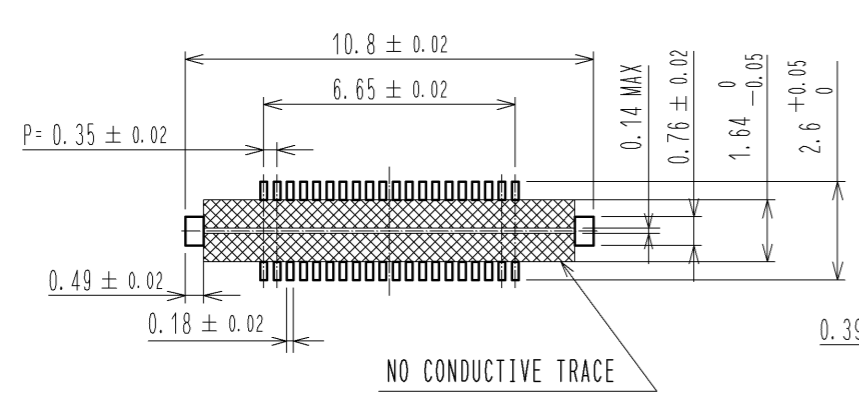

◆ RECOMMENDED METAL MASK DIMENSIONS

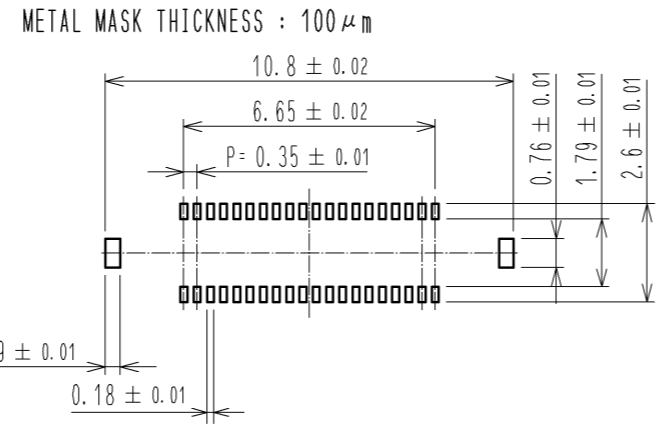

4	PS	CLEAR(EMBOSSED CARRIER TAPE)						
3	COPPER ALLOY	2	7	PS	CLEAR (REINFORCEMENT COLLAR)			
2	PHOSPHOR BRONZE	2	6	PS	BLACK (PLASTIC REEL)			
1	LCP	UL94 V-0. BLACK	5	POLYESTER	CLEAR (COVER TAPE)			
NO.	MATERIAL	FINISH . REMARKS	NO.	MATERIAL	FINISH . REMARKS			
UNITS	mm	SCALE	10 : 1	COUNT	DESCRIPTION OF REVISIONS	DESIGNED	CHECKED	DATE
HRS HIROSE ELECTRIC CO., LTD.		APPROVED : KH. IKEDA	14. 04. 04	DRAWING NO. EDC3-357614-01				
		CHECED : WR. FUKUCHI	14. 04. 04	PART NO. BM24-40DS/2-0. 35V(51)				
		DESIGNED : YH. HASEGAWA	14. 04. 04	CODE NO. CL677-2010-0-51				
		DRAWN : YH. HASEGAWA	14. 04. 04					

EMBOSSED CARRIER TAPE PACKAGING (FREE)

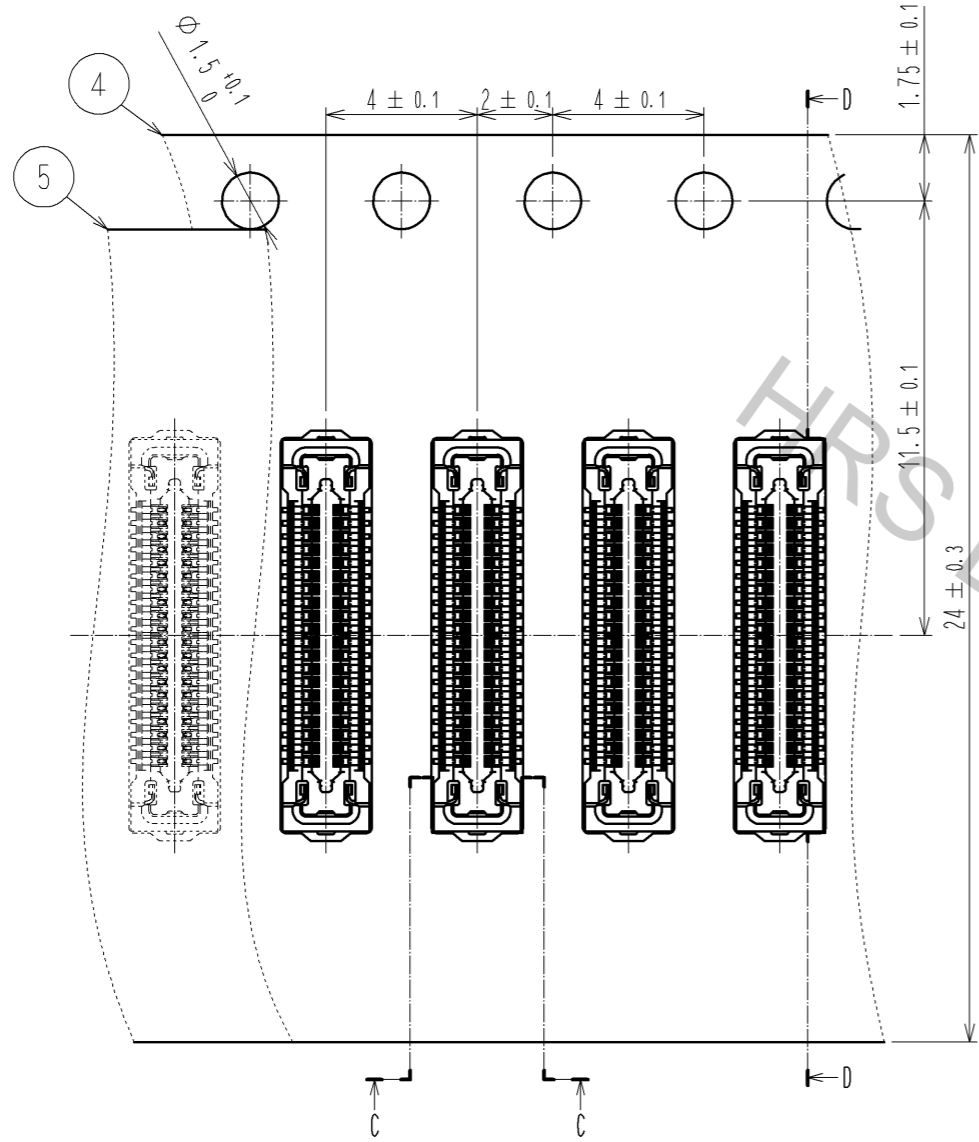

C-C (5:1)

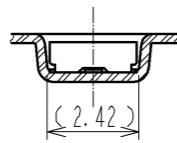

DIRECTION OF UNREELING

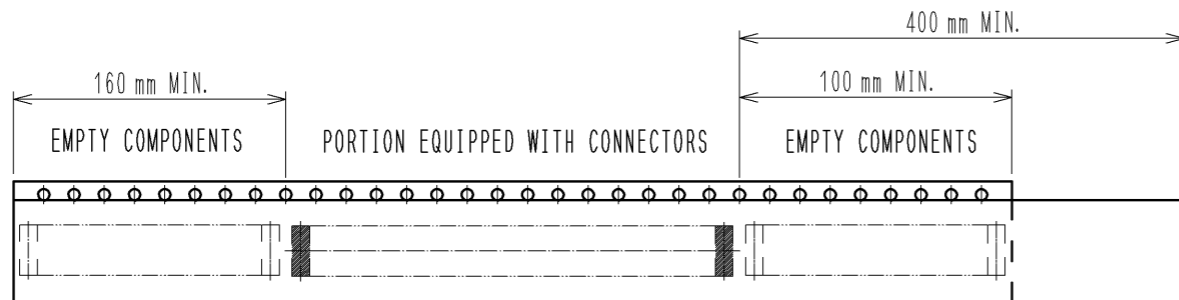
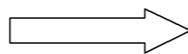

TRAILER

9 TAPING (FREE)

LEADER

STYLE AND DIMENTION OF REEL (FREE)

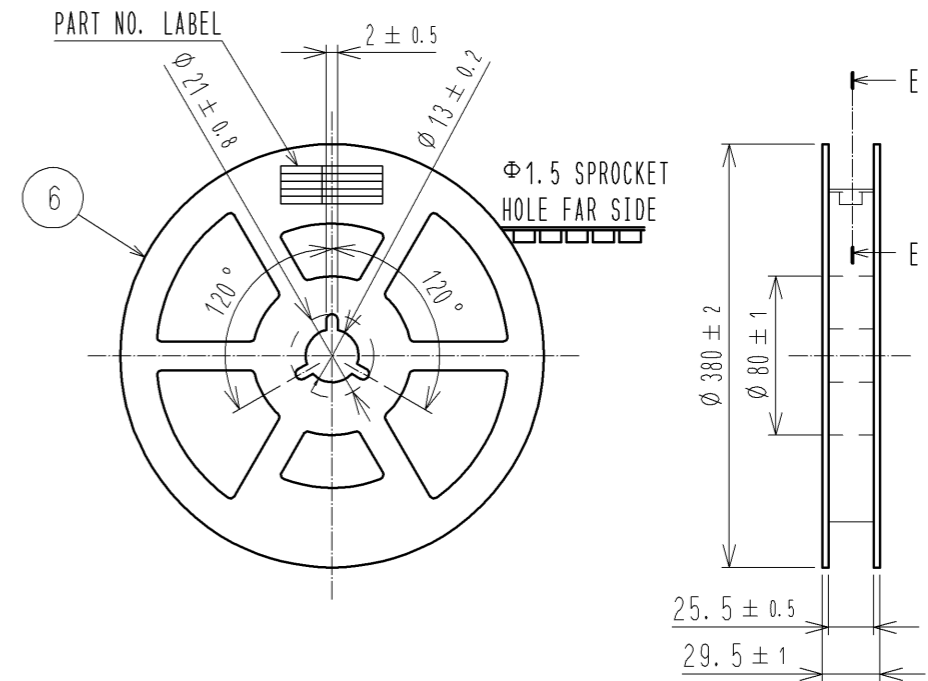

E-E (FREE)

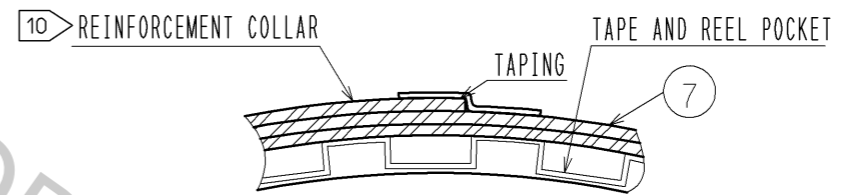

DETAIL OF PART NO. LABEL

製造年月日	** ** *
製品コード	CL0677-2010-0(51)
製品名	BM24-40DS/2-0.35V(51)
数量	10.000
納入者	ヒロセ電機(株)

DATA OF MANUFACTURED
CODE NO.
PART NO.
QUANTITY
SUPPLIER

7 . PER REEL 10,000 CONNECTORS.

8 . THE DIMENSIONS IN PARENTHESES ARE FOR REFERENCE.

9 . REFER TO JIS C 0806(PACKAGING OF COMPONENTS FOR AUTOMATIC HANDLING)

10 . AFTER PACKAGING. ROLL 2 METERS OF THE REINFORCEMENT COLLAR TO OUTER CIRCUMFERENCE OF TAPE AND REEL POCKET. AND TAPE DOWN AT THE END THE COLLAR.

HRS

DRAWING NO.	EDC3-357614-01	
PART NO.	BM24-40DS/2-0.35V(51)	
CODE NO.	CL677-2010-0-51	△ 2/2