

4
DRAWING MADE IN THIRD ANGLE PROJECTION
THIS DRAWING IS UNPUBLISHED. RELEASED FOR PUBLICATION .19
© COPYRIGHT 19 BY AMP INCORPORATED. ALL INTERNATIONAL RIGHTS RESERVED.

LOC	DIST	P	F	ZONE	LTR	DESCRIPTION	DATE	APPO
AJ	16							
		✓	✓		D	REDWN & ADD 1--6 & 1--7 PER AJ-4560	2-15-91	BAS
		✓	✓		E	REVISED PER EC 0130-0095-93	2-23-93	MEC

- ① BRASS PER QQ-B-626
- ② GOLD PLATE PER MIL-G-45204
0.76µm [.000030] MINIMUM THICK
- ③ GOLD PLATE PER MIL-G-45204
1.27µm [.000050] MINIMUM THICK
- ④ GOLD PLATE PER MIL-G-45204
2.54µm [.000100] MINIMUM THICK
- ⑤ SILVER PLATE PER QQ-5-365
2.54µm [.000100] MINIMUM THICK

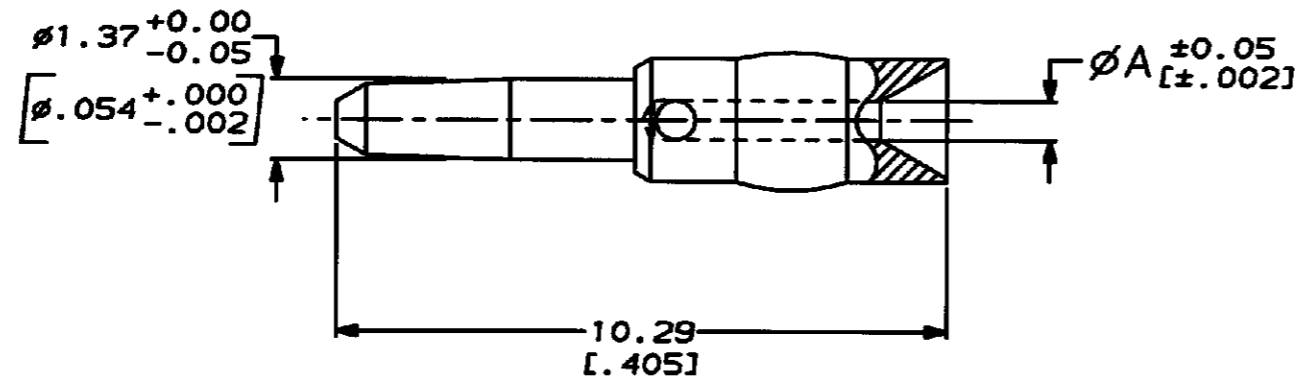

1.09 [.043]	④	1-331357-7
0.99 [.039]	④	1-331357-6
0.99 [.039]	⑤	1-331357-5
1.09 [.043]	②	1-331357-4
0.99 [.039]	②	1-331357-3
1.09 [.043]	③	1-331357-2
0.99 [.039]	③	1-331357-0
A	FINISH	PART NUMBER

DO NOT SCALE PRINT. UNLESS SPECIFIED DIMENSIONS IN IN (INCHES) TOLERANCES ON: 2 PLC DEC ± 0.13 (.005) 3 PLC DEC ± - ANGLES ± -		DR 2-15-91 B. SCOTT CHK 3-30-91 J. LIPPERT APPO 4-3-91 H. PHILLIPS APPO 4-3-91 J. LIPPERT PRODUCT SPEC - APPLICATION SPEC - MFGT -		PART NO	
MATERIAL ①		AMP Incorporated Harrisburg, PA 17105-3608		NAME	
FINISH SEE TABLE		CONTACT, PLUG, SERIES BNC		DRAWING NO	
		SIZE B	CAGE CODE 00779	331357	
		SCALE 10:1	SHEET 1 OF 1		