

THIS DRAWING IS UNPUBLISHED. RELEASED FOR PUBLICATION .19
 (C) COPYRIGHT 19 BY AMP INCORPORATED. ALL RIGHTS RESERVED.

| LOC | | DIST | | REVISIONS | | | |
|-----|-----|----------------------|------|-----------|------|--|--|
| P | LTR | DESCRIPTION | DATE | DWN | APVD | | |
| | C | REV PER 063D-0012-01 | 7-03 | CT | DM | | |

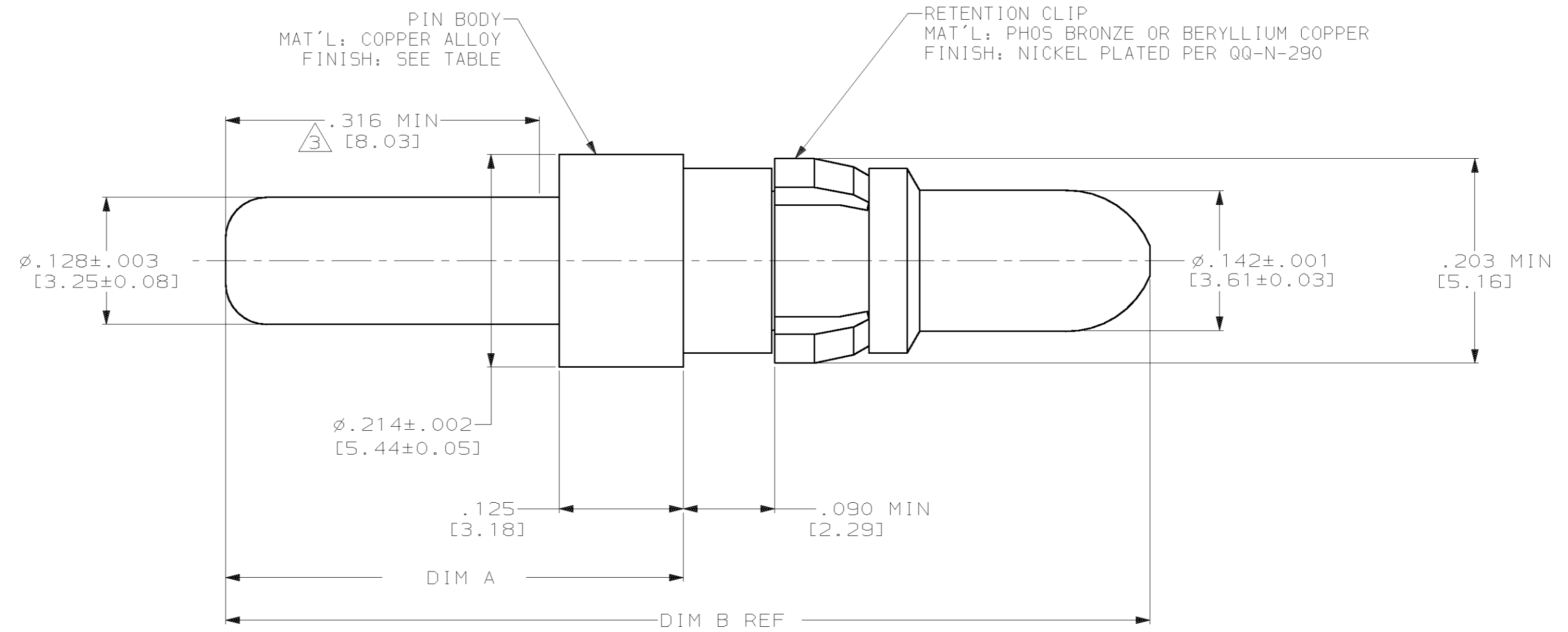

| | | | | |
|---|---------------|--------------|--------------|-------------|
| PRELIMINARY NOT RELEASED FOR PRODUCTION | $\triangle 2$ | .845 [21.46] | .375 [9.53] | 1-449379-1 |
| PRELIMINARY NOT RELEASED FOR PRODUCTION | $\triangle 2$ | .931 [23.65] | .461 [11.71] | 1-449379-0 |
| | $\triangle 1$ | .845 [21.46] | .375 [9.53] | 449379-2 |
| | $\triangle 1$ | .931 [23.65] | .461 [11.71] | 449379-1 |
| | FINISH | DIM B | DIM A | PART NUMBER |

- $\triangle 1$ FINISH: PLATED GOLD .000050 [0.00127] MIN THK PER MIL-G-45204 OVER NICKEL .000050 [0.00127] MIN THK PER QQ-N-290.
- $\triangle 2$ FINISH: PLATED GOLD .000030 [0.00076] MIN THK PER MIL-G-45204 OVER NICKEL .000050 [0.00127] MIN THK PER QQ-N-290.
- $\triangle 3$ THIS AREA SHALL SATISFY THE REQUIREMENTS OF MIL-STD-202, METHOD 208.
- 4. THIS CONTACT CAN BE USED IN ANY AMPLIMITE PLUG CONNECTOR WITH SIZE 8 CONTACT CAVITIES.

| | | | |
|--|--|--------------------------------|---|
| THIS DRAWING IS A CONTROLLED DOCUMENT. | | DWN C.C. THOMAS 11/10/00 | AMP AMP Incorporated Harrisburg, PA 17105-3608 |
| DIMENSIONS: INCHES [mm] | | CHK D. MILLER 11/10/00 | |
| TOLENCES UNLESS OTHERWISE SPECIFIED: | | APVD D. MILLER 11/10/00 | NAME ASSEMBLY, PIN CONTACT SIZE 8, STRAIGHT POST, PCB |
| 0 PLC ±- 1 PLC ±- 2 PLC ±- 3 PLC ±.005 [0.13] 4 PLC ±- ANGLES ±- ±- | | PRODUCT SPEC - | SIZE A2 |
| MATERIAL SEE CALLOUTS | | FINISH SEE TABLE | CAGE CODE 00779 |
| | | WEIGHT - | DRAWING NO 449379 |
| | | CUSTOMER DRAWING | RESTRICTED TO - |
| | | SCALE 10:1 | SHEET 1 OF 1 |
| | | | REV C |