

Description	Material	Finish
Body	Brass	Gold
Socket	BE CU	Gold
Insulation	PTFE	N/A
Crimp Ring	Brass	Gold
Heat Shrink	Polyolefin	Black

REVISIONS			
REV	DESCRIPTION	DATE	APPV
B	Added new title block and heat shrink; updated instructions	11-JUL-12	SAH
C	Updated Assembly Instruction 4 and Note 3	2-NOV-17	CLL

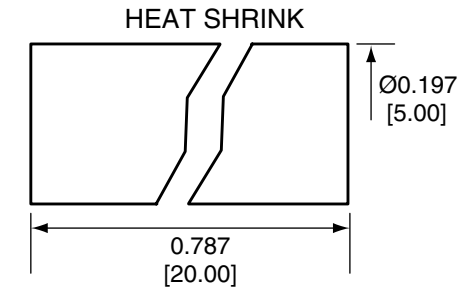
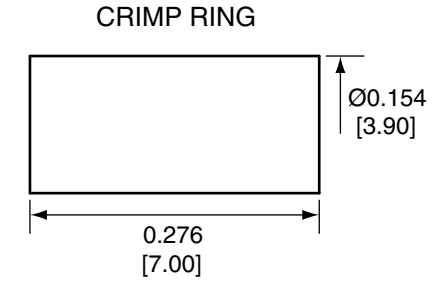
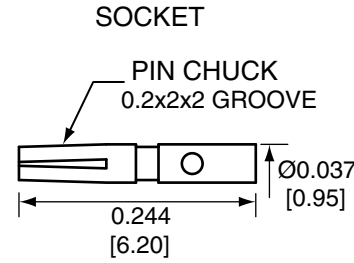
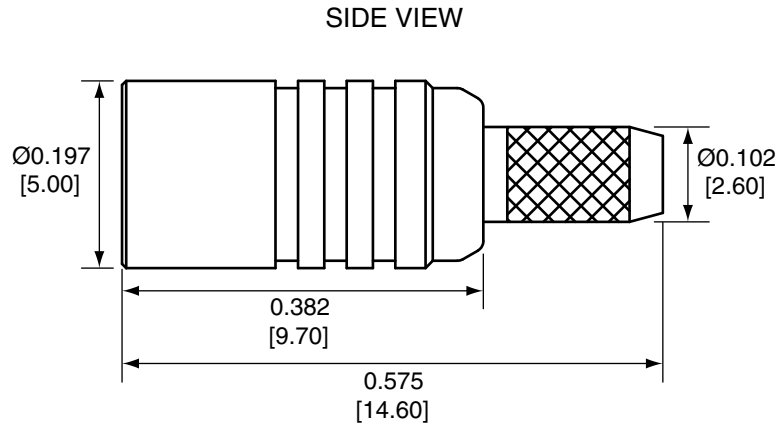

CONMCX011 ASSEMBLY INSTRUCTIONS

1. Strip cable to recommended dimensions.
2. Slip heat shrink and crimp ring onto stripped cable.
3. Solder the socket to the center conductor.
4. Insert the socket and center conductor into the body until the socket snaps in.
5. Wrap the braid around the tail of the body and crimp the ring with a 0.128" hex crimp tool (or one labeled for use with RG-174 cable).
6. Use heat shrink to cover crimp.

RECOMMENDED CABLE STRIPPING DIMENSIONS

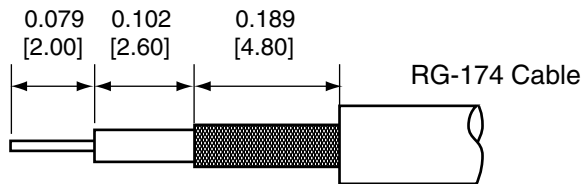

NOTES: (UNLESS OTHERWISE SPECIFIED)

1. ALL DIMENSIONS ARE IN INCHES [mm].
2. DIMENSIONS APPLY AFTER FINISHING.
3. MANUFACTURE TO BE COMPLIANT WITH EU RoHS DIRECTIVE, USE MATERIALS THAT DO NOT CONTAIN REACH SUBSTANCES OF VERY HIGH CONCERN >1000ppm, AND USE DRC CONFLICT-FREE SOURCED MATERIALS.
4. SAFETY BREAK ALL SHARP CORNERS AND EDGES .02 MAXIMUM.

WARNING: THIS DRAWING CONTAINS PROPRIETARY INFORMATION THAT IS THE SOLE PROPERTY OF LINX TECHNOLOGIES, AND SHALL BE TREATED AS SUCH. NO DISCLOSURE OR REPRODUCTION OF THIS DOCUMENT IS PERMITTED, IN WHOLE OR IN PART, WITHOUT THE EXPRESS WRITTEN PERMISSION OF LINX TECHNOLOGIES OR ITS DESIGNATED AGENTS.

MATERIAL:	TOLERANCES: .020 [0.50]-.200 [5.00]= ±.008 [0.20] .200 [5.00]-1.200 [30.00]= ±.016 [0.40] 1.20 [30.0]-4.75 [120.0]= ±.024 [0.60] 4.75 [120.0]-12.40 [315.0]= ±.040 [1.0]	PROJECTION: 
FINISH:	DRAWN: B.MURPHY DT: 11-JUL-12	ANGLES: ±1°
	ENGR: S.HOGAN DT: 11-JUL-12	

		159 ORT LANE MERLIN, OR 97532	
		TITLE: MCX FEMALE CABLE END CRIMP FOR RG174 CABLE	
SIZE A	DWG. NO. CONMCX011	REV C	
SCALE: 2:1	DO NOT SCALE DRAWING	SHEET 1 OF 1	