

PART NAME: KNOB SCALE: 1:1 DATE: 3/6/09 DR. BY JAM

DAVIES MOLDING COMPANY
CAROL STREAM, ILLINOIS 60188

P/N	1507-C
MOLD #	1507
CAVITY	1507
CORE	1507
PIN	1507-C
SPRING	I1125A

THIS DRAWING IS THE PROPERTY OF DAVIES MOLDING COMPANY, IS SUBMITTED SOLELY AS A DESIGN OR ENGINEERING PROJECT.
WE ACCEPT NO RESPONSIBILITY WHATSOEVER FOR THE PRACTICAL APPLICATION OF THE PIECES MADE TO THIS DESIGN.

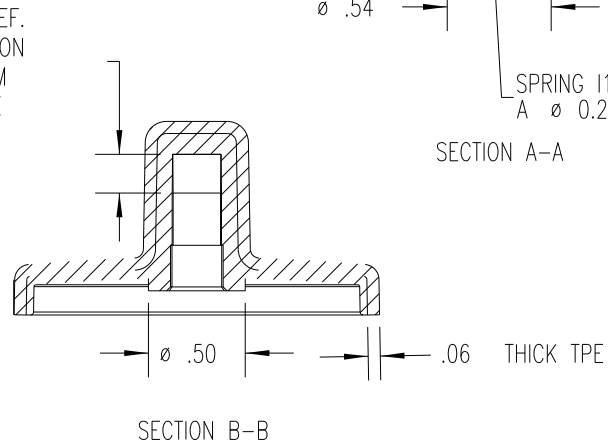
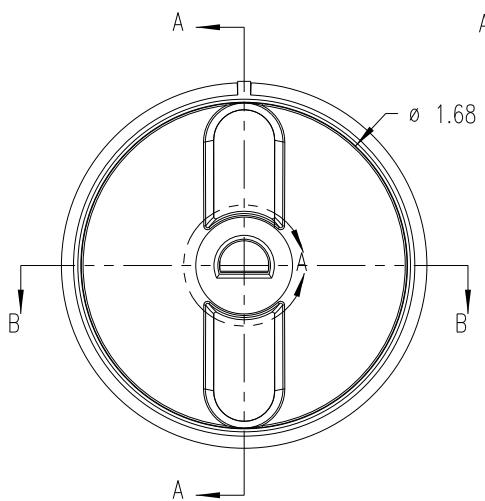
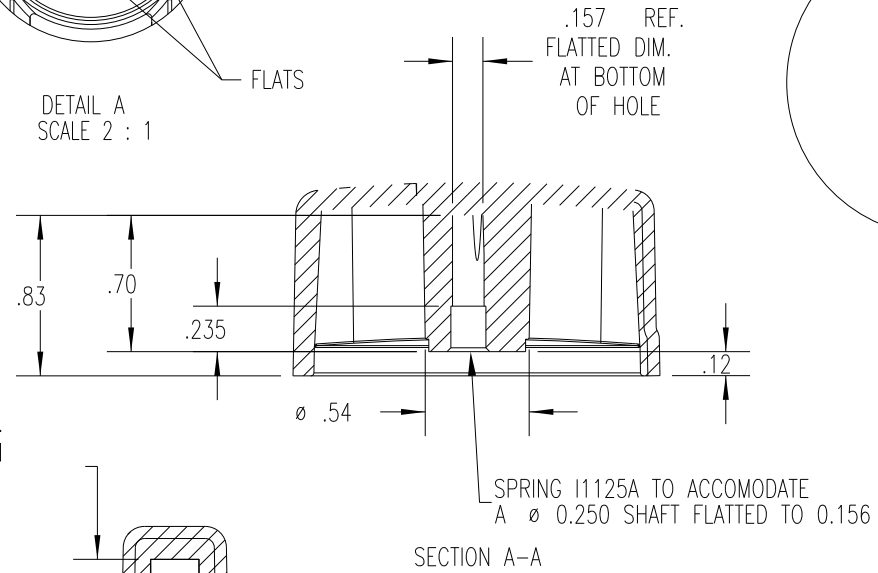
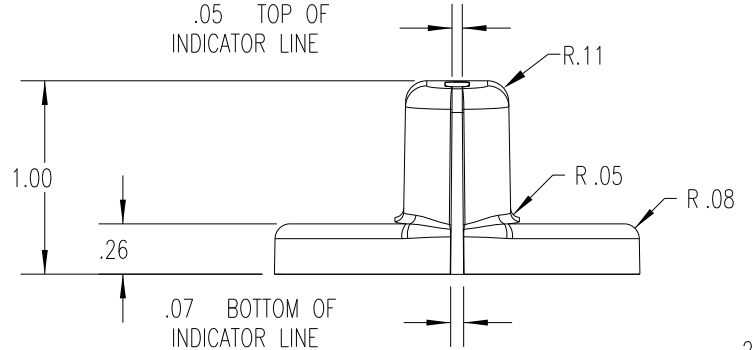
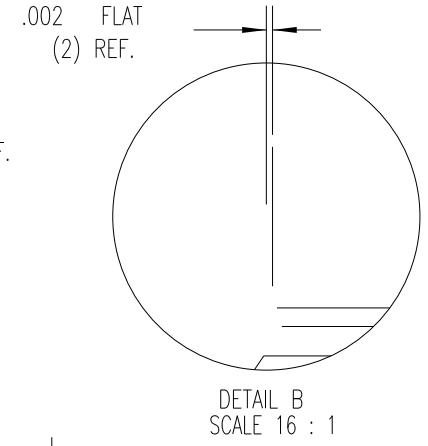
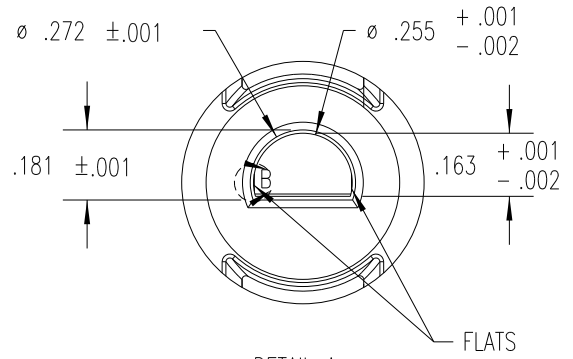
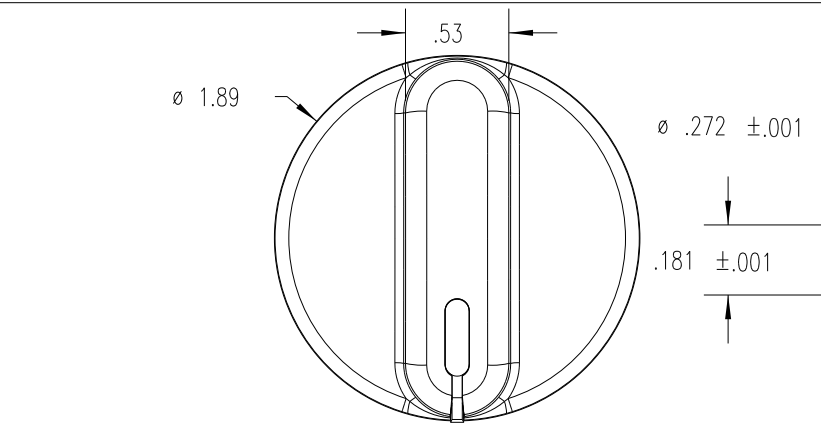

SUBSTRATE MATERIAL: 33% GLASS FILLED NYLON (CL5)
COLOR: WHITE (SWGfNYWH) (A)
OVERMOLD MATERIAL: TPE (TPE1)
COLOR: BLACK (PC-301)

TOLERANCES: UNLESS OTHERWISE SPECIFIED	DO NOT SCALE DRAWING			
DECIMALS: X.XXX ± .005 X.XX ± .015	MM: X.XX ± 0.15MM X.X ± 0.4MM	A	WAS WTB8000	JAM 10/15/15
FRACTIONS ± 1/64	ANG. ± 1°	-	WAS SK1507-10	JAM 3/6/09
CHANGES				